

30.12

cod. 1201200

1201200_3012_0 260700

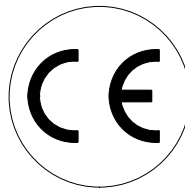

Manuale d'uso, manutenzione e parti di ricambio	Parte 2
Use, maintenance and spare parts manual	Part 2
Gebrauchsanweisung, Instandhaltungsrichtlinien und Ersatzteile	Teil 2
Manuel d'utilisation, entretien et pièces de rechange	Partie 2
Manual de uso, mantenimiento y repuestos	Part 2
Εγχειρίδιο χρήσης, συντηρησης και ανταλλακτικών	2° Μερὸς
Manual de utilização, manutenção e partes sobresselentes	Parte 2
Handleiding voor gebruik, onderhoud en reservedelslste	Deel 2
Brugsanvisning, vedligeholdelse og reservedelslste	Del 2

Dati tecnici

Technical data
Technische daten

Données techniques

Datos tècnicos
Τεχνικά χαρακτηριστικά

Dados tècnicos

Technische gegevens
Teknische data

Misure impiegabili mm Usable lengths mm Gebrauchliche Längen mm	Mesures utilisable mm Medidas que se pueden emplear mm Διαστάσεις σε μμ	Medidas que se podem utilizar mm Te gebruiken engtes in mm Brugbare laengder i mm	13÷30
Capacità caricatore n° punti Magazine capacity No. of fasteners Magazinkapazität Nägel	Capacité chargeur n° de points Capacidad cargador n° puntos Δυνατότητα γεμιστέρα, σπνδτερες	Capacidade carregador n° pontos Capaciteit magazijn in aantal spijkers Kapasitet af magasin antal klemme	120
Pressione d'esercizio Working pressure Betriebsdruck	Pression de fonctionnement Presión de trabajo Πίεση λειτουργιασ ατμ.	Pressao de trabalho Werkdruk Arbejds tryk bar	5÷6.5 bar 70÷95 psi
Consumo aria litri/colpo Air consumption litres/shot Luftverbrauch Liter/Schlag	Consommation air litre/coup Consumo aire-litros/golpe Καταναλοση αερα λ/ξτπημα	Consumo ar litro/golpe Luchtverbruik liter/schot Luftforbrug liter/skud	0,24
Peso kg Weight kg Gewicht kg	Poids kg Peso kg Βαρος κγ	Peso kg Gewicht in kg Vaegt kg	1,4
Dimensioni (AxBxH) mm Dimensions mm GroÙe mm	Dimension mm Dimensiones mm Δυνατότητα γεμιστέρα, σπνδτερες	Dimencoes mm Afmetingen in mm Dimensioner mm	255x45x200
ISO 11201 Pressione sonora in pos. operatore Sound pressure at the workstation Lärmintensität am Arbeitsplatz	ISO 11201 Pression acoustique près de l'opérateur Presión sonora en posición encargado Ακουστικη πιεση στη θεση χειριστου	ISO 11201 Intensidade sonora perto do operador Geluidssterkte op de werkplek Lydstyrke på operatorposten	85,2 dB(A)
ISO 3744 Potenza sonora emessa Emitted sound power Ausgestrahlte Lärmintensität	ISO 3744 Puissance acoustique émise Potencia sonora emitida Ακουστικη ισχυ	ISO 3744 Potência sonora emitida Uitgestraalde geluidssterkte Udsendt lydstryrke	97,5 dB(A)
ISO 5349-86 Valore medio ponderato di vibrazione sull'impugnatura max.33 colpi Weighted mean value of vibration on the grip max.33 shots Mittler Vibrationswert, am Griff gemessen max.33 Schläge	ISO 5349-86 Valeur moyenne pondérée de vibration mesurée sur la poignée max.33 coups Valor medio ponderado de vibracion medida en la empuñadura max.33 golpe Μεσοσ οροσ μετρησησ κραδασιου στη χειρολαβη μαξ.33 ξτπημα	ISO 5349-86 Valor medio ponderado de vibracao medida no punho max.33 golpes Gewogen gemiddelde vibratiewaarde max.33 schot Middelvaerdi af vibrationer på handtaget max.33 skud	<2,5 m/s²

Tipo di punto
Type of fastener
Befestigungselement
Type d'agrafe
Tipo de punto
Τυπος καρφιου
Tipo de ponto
Type nietjes
Tilspændingstype

Brads 12

1x1,25

1,9

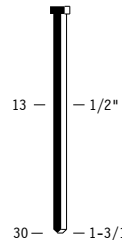

Head width: 0.075"
Thickness: 0.040"
Width: 0.050"
Gauge: 18

Parti di ricambio - Spare parts - Ersatzteile - Pièces de rechange - Piezas de repuesto
 Ανταλλακτικά - Partes sobresselentes - Tabel te raadplegen - Reservedede

Cod.	Descrizione	Description
00.07	O-Ring	O-Ring
00.09	O-Ring	O-Ring
00.14	O-Ring	O-Ring
00.18	O-Ring	O-Ring
01.35	O-Ring	O-Ring
01.38	O-Ring	O-Ring
02.28	O-Ring	O-Ring
04.10	Vite	Screw
04.12	Vite	Screw
04.18	Vite	Screw
04.20	Vite	Screw
04.30	Vite	Screw
07.30	Chiave esagonale	Hex. Bar wrench
09.02	Anello elastico	Elastic ring
09.03	Anello elastico	Elastic ring
09.13	Rondella	Washer
09.14	Rondella	Washer
09.18	Anello elastico	Elastic ring
13.14	Spina	Pin
17.10	Attacco rapido 1/4"	Air plug 1/4"
21.24	Corpo (specificare il colore)	Body (to specify the colour)
22.20	Testa (specificare il colore)	Head (to specify the colour)
25.20	Deflettore	Exhaust deflector
26.20	Cilindro	Cylinder
30.22	Pistone	Piston
32.20	Ammortizzatore	Bumper
39.00	Guarnizione	Gasket
40.20	Valvola completa	Valve ass'y
41.20	Pistone valvola	Valve
42.20	Gambo valvola	Valve cylinder
43.18	Rondella	Washer
44.20	Guarnizione	Gasket
50.40	Pulsante completo	Trigger valve ass'y
52.40	Portamolla	Washer
54.40	Pulsante	Trigger valve
55.40	Raccordo	Bush
56.14	Guarnizione	Gasket
71.20	Staffa	Support
75.24	Sicura	Safety
76.05	Perno	Pin
76.06	Perno	Pin
77.21	Guida sicura	Safety guide
80.04	Grilletto chiusura	Trigger
81.70	Grilletto comando	Trigger
81.71	Leva grilletto	Trigger lever
90.02	Molla	Spring
91.20	Molla	Spring
92.00	Molla	Spring
93.21	Molla	Spring
21.20.19	Battente	Driver
31.20.19	Guida battente	Drive guide
41.20.19	Caricatore completo	Magazine ass'y
51.20.19	Caricatore	Magazine
61.20.19	Carrello	Slider
71.20.19	Spingipunto	Pusher
91.20.19	Testina	Nose plate

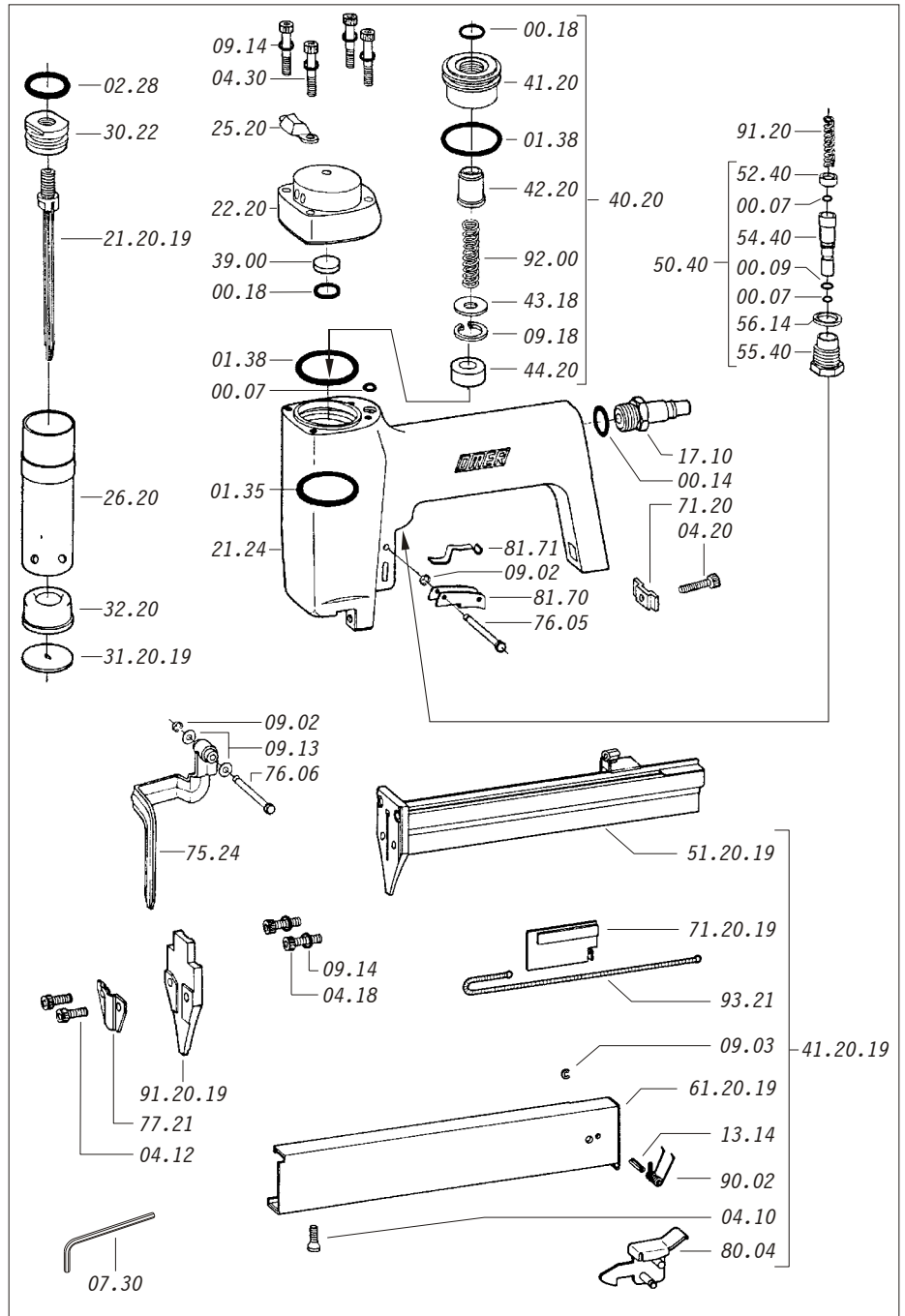

Guarnizioni - O-Rings - Dichtungen - Joints - Empaquetadura de anillo - Λαστιχακια - Kit de o-rings - O-ringen - Pakninger

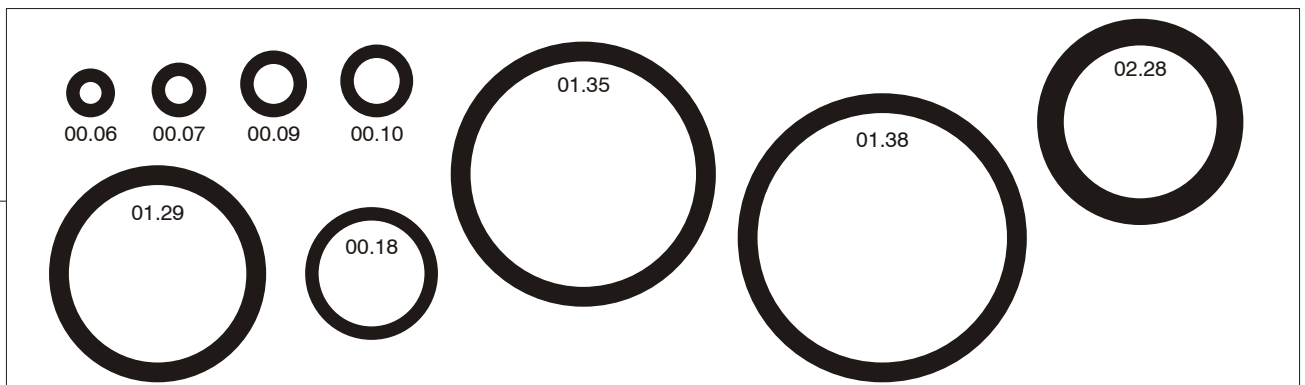

30.12

cod. 1201200

Indice di modifica
Upgrade number

0