



## Istruzioni d'uso - How using the tool

### COME CARICARE LE GRAFFE

- 1 - Tirare lo spingipunto (32P035) fino alla fine del caricatore (35P030N). Farlo quindi ruotare verso il basso fino a toccare la parte inferiore del caricatore.
- 2 - Inserire le graffe in modo corretto nel caricatore a partire dalla parte posteriore.
- 3 - Alzare lo spingipunto e farlo scorrere contro le graffe.



### UTILIZZO

- 1 - Appoggiare la graffatrice sul cartone da chiudere.
- 2 - Premere a fondo la leva (35M002).
- 3 - Rilasciare la leva, e solo a questo punto spostare la graffatrice in altra posizione. Muovere la graffatrice con la leva abbassata può causare la rottura delle ganasce (35P021 - 35P022).

### REGOLAZIONE IN BASE ALLA LUNGHEZZA DELLA GRAFFA

- 1 - Allentare il grano (35P063).
- 2 - Girare la vite (35P018) posizionandola con la "S" in alto graffe corte o con la "L" in alto per graffe lunghe.
- 3 - Stringere di nuovo il grano (35P063). (Vedi Fig. 1)

Fig. 1

15 mm	18 mm
16 mm	19 mm
	

### REGOLAZIONE DI PROFONDITÀ

- 1 - Allentare le viti (35M038N).
- 2 - Far scorrere la piastra frontale (35M014N) verso l'alto o il basso. (Vedi Fig. 2)
- 3 - Chiudere le viti.

Fig. 2

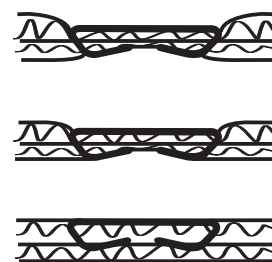

### REGOLAZIONE DELLA CHIUSURA

- 1 - Allentare la ghiera (35M011).
- 2 - Svitare la vite (35M010) per una maggiore ribaditura e avvitarla in caso contrario.
- 3 - Stringere di nuovo la ghiera (35M011). (Vedi Fig. 3)

Fig. 3

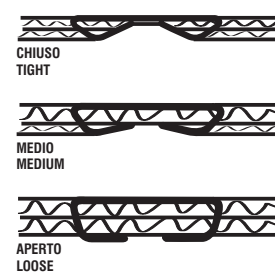

### HOW LOADING THE STAPLES

- 1 - Pull the pusher (35P035) back to the end of the magazine (35P030) and turn the pusher downward until reaching the bottom of the magazine.
- 2 - Insert the staples into the magazine from the rear to the front.
- 3 - Turn the pusher upward and release it against the staples.

### USE OF THE STAPLER

- 1 - Lean the tool against the cardboard you want to staple
- 2 - Push the handle (35M002) downwards
- 3 - Release completely the handle upwards and then shift the stapler over another position for next stapling. Never shift stapler with the handle downwards to prevent the breakage of the jaws.

### HOW SETTING THE TOOL TO THE STAPLE LEG SIZE BEING USED (Picture no.1)

- 1 - Loose bolt 35P063 off.
- 2 - Turn the adjusting rod and set "S" when using shorter staples leg sizes or "L" when using the longest ones.
- 3 - Tighten bolt 35P063

### HOW ADJUSTING THE DEPTH (Picture no. 2)

- 1 - Loose bolts 35M038N.
- 2 - Slide front plate 35M014N upward or downward for less or deeper penetration.
- 3 - Tighten bolts 35M038N.

### HOW ADJUSTING CLINCHING (Picture no. 3)

- 1 - Loose adjusting nut 35M011
- 2 - Turn screw 35M010 clockwise for a tight clinching or counterclockwise for a loose clinching
- 3 - Tighten adjusting nut 35M011

## Parti di ricambio - Spare parts

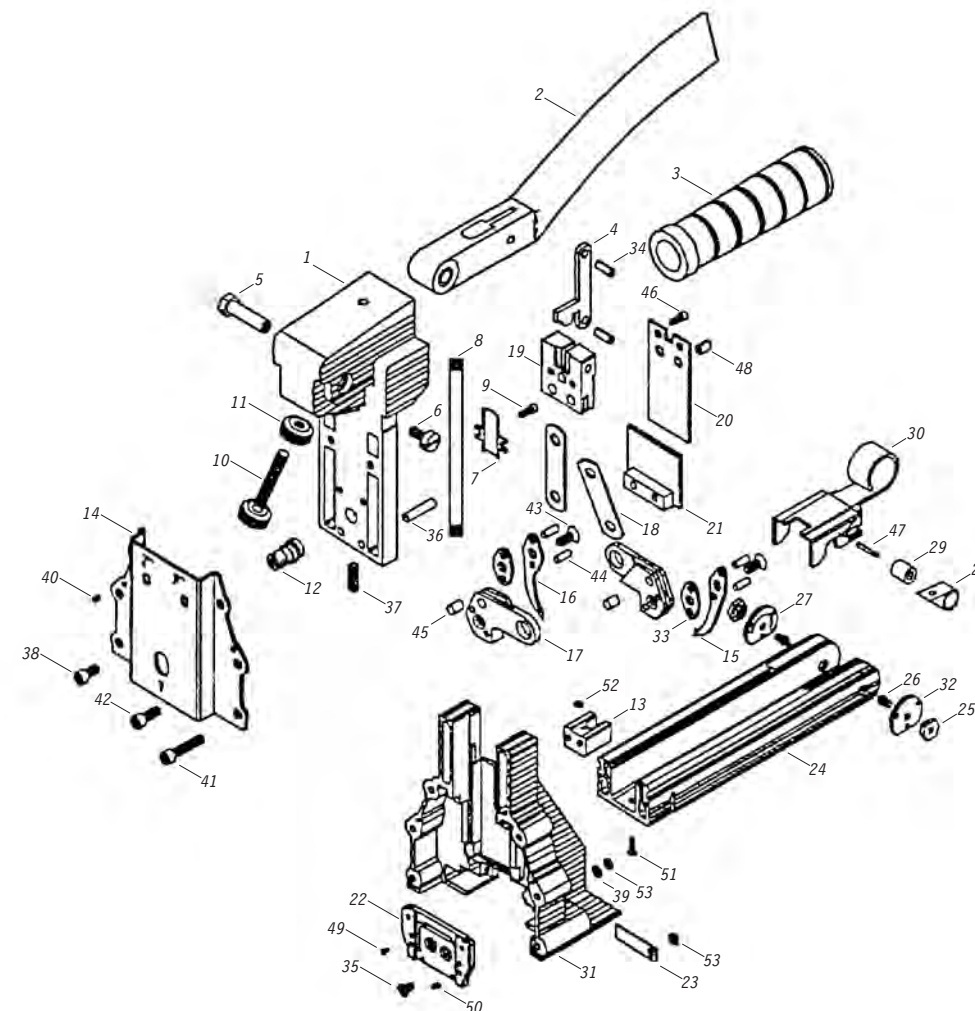

Ref. No.	Part No.	Description	Ref. No.	Part No.	Description
1	35M001N	Body	28	35P033	Spring
2	35M002	Handle	29	35P034	Roller
3	35M003	Handle gleeve	30	35P035	Pusher unit
4	35M004N	Link	31	35P036	Magazine seat
5	35M005	Pivot pin	32	35M032	Left pusher guide
6	35M006	Pivot screw	33	35P039	Washer
7	35M007N	Cover	34	35M034N	Spring pin
8	35M008N	Spring	35	35P082N	Screw
9	35P048	Bolt	36	35P062	Rod
10	35M010	Adjusting screw	37	35P063	Bolt
11	35M011	Adjusting nut	38	35M038N	Bolt
12	35P018	Adjusting rod	39	35P078	Washer
13	35P083N	Bracket	40	35P066	Spring pin
14	35M014N	Front plate	41	35P067	Bolt
15	35P021	Right jaw	42	35P068	Bolt
16	35P022	Left jaw	43	35P069	Screw
17	35P023	Jaw seat	44	35P070	Pin
18	35P024	Plate	45	35P071	Pin
19	35M019	Block	46	35M046N	Bolt
20	35P026	Driver	47	35P079	Spring pin
21	35M021N	Cover unit	48	35P072	Spring pin
22	35M022	Driver guide unit	49	35P073	Screw
23	35P029	Plate	50	35P074	Spring pin
24	35P030	Magazine	51	35P075	Screw
25	35P031	Rod nut	52	35P076	Lock nut
26	35P032	Rod	53	35P077	Lock nut
27	35P037	Right pusher guidet			

35.18 M

cod. 19818MT

19818MT\_3518M\_270505

35.18 M

cod. 19818MT

Indice di modifica  
Upgrade number

0