

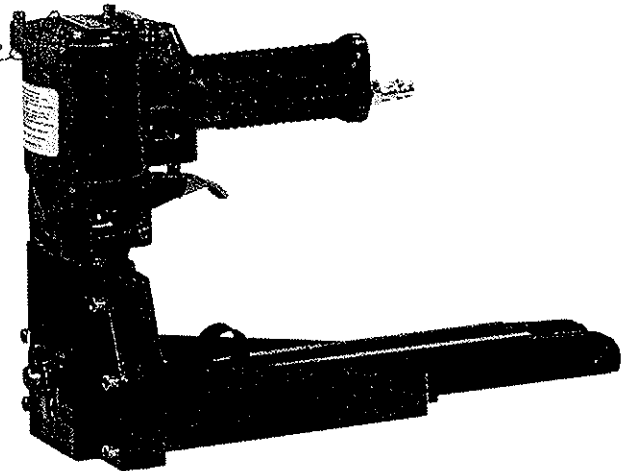

achat 24/10/2014  
 Levu par Marec

MODEL **35.22**  
 SERIAL NUMBER **307159**  
 ANNO DI COSTRUZIONE  
 MANUFACTURED IN **2013**

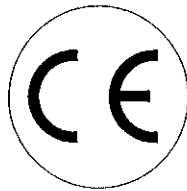

**Manuale d'uso,  
 manutenzione e parti di ricambio**  
**Use, maintenance and spare  
 parts manual**

**35.22**

cod. 19822T3

**Dati tecnici**  
 Technical data

**Indice di modifica**  
 Upgrade number

**3**

<b>Misure impiegabili mm</b> Usable lengths mm	<b>18+22</b>
<b>Capacità caricatore n° punti</b> Magazine capacity No. of fasteners	<b>100</b>
<b>Pressione d'esercizio</b> Working pressure	<b>5+7 bar</b> <b>70+ 100 psi</b>
<b>Consumo aria litri/colpo</b> Air consumption litres/shot	<b>1,32</b>
<b>Peso kg</b> Weight kg	<b>2,50</b>
<b>Dimensioni (AxBxH) mm</b> Dimensions mm	<b>342x115x222</b>
ISO 11201	
<b>Pressione sonora in pos. operatore</b> Sound pressure at the workstation	<b>84,3 dB(A)</b>
ISO 3744	
<b>Potenza sonora emessa</b> Emitted sound power	<b>93,7 dB(A)</b>
ISO 5349-86	

**Tipo di punto**  
 Type of fastener

**35**

0,80x2,20

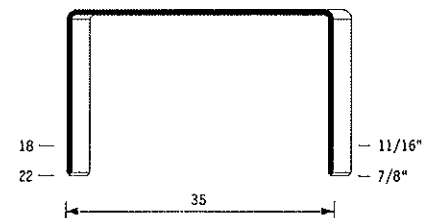

Gauge: 16

Crown: 1.378" (1-3/8")

# Parti di ricambio - Spare parts

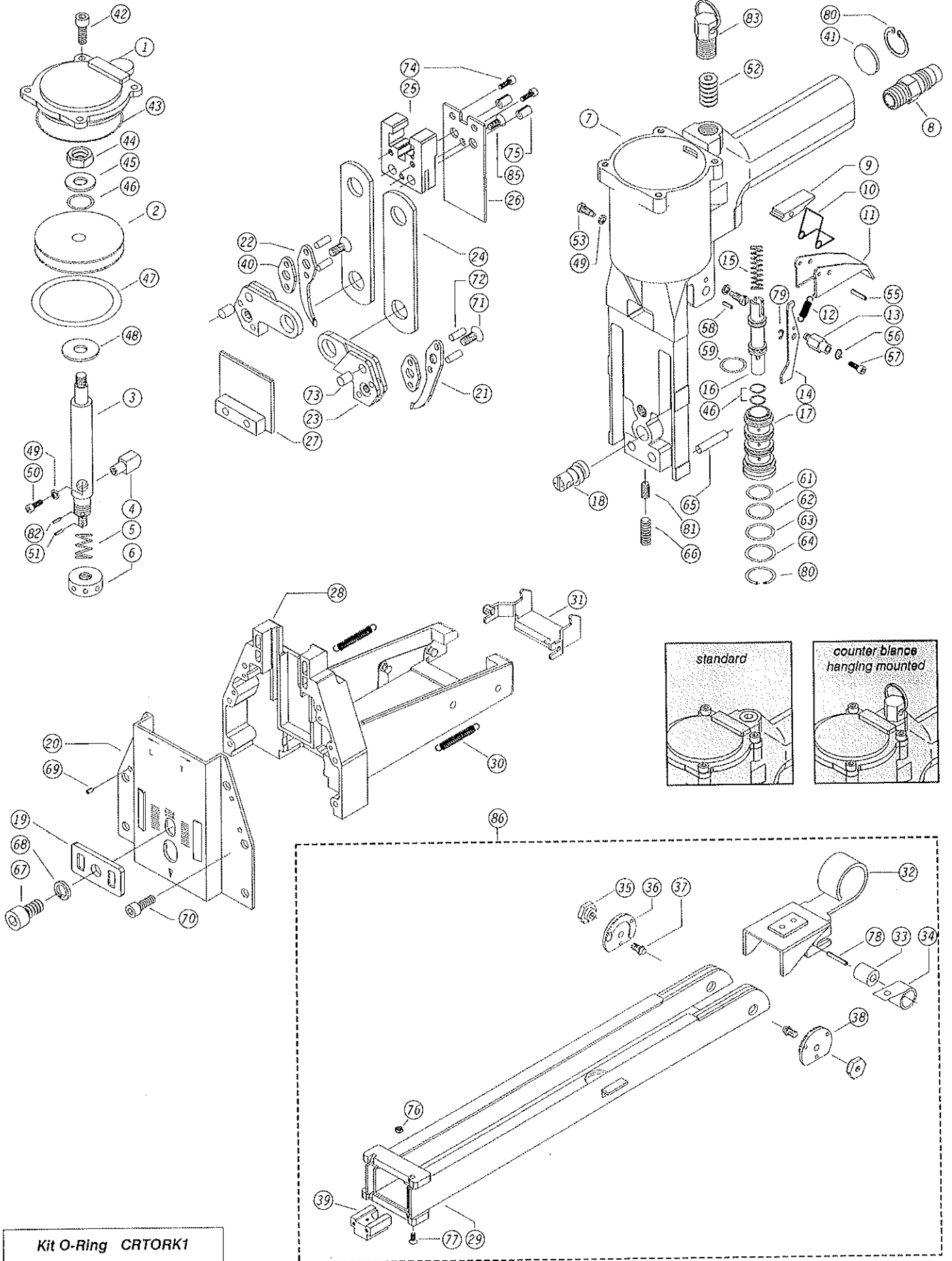

**Kit O-Ring CRTORK1**

4	35P004	Block
5	35P005	Spring
6	35P006	Collar
7	35P007N	Body
8	35P008	Air Plug
9	35P009	Block
10	35P010	Spring
11	35P011	Trigger
12	35P012	Spring
13	35P013	Rod
14	35P014	Trigger's control
15	35P015	Spring
16	35P016	Valve
17	35P017N	Tube
18	35P018	Adjusting Rod
19	35P019	Adjusting Plate
20	32P520	Front plate
21	35P0212	Right jaw
22	35P0222	Left jaw
23	35P023	Jaw seat
24	35P024	Plate
25	32P525	Block
26	35P5182	Driver
27	35P027	Cover Unit
28	32M320	Magazine Seat
29	35P329	Magazine
30	32M522	Spring
31	32M523	Bracket
32	35P035	Pusher Unit
33	35P034	Roller
34	35P033	Spring
35	32P535	Rod Nut
36	35P037	Right pusher guide
37	35P032	Rod
38	35M032	Left pusher guide
39	32M531	Bracket
40	35P039	Washer
41	32P541	Silencer
42	35P040N	Screw
43	35P042N	O-Ring
44	35P043	Nut
45	35P044	Washer
46	35P045	O-Ring
47	35P046N	O-Ring
48	35P047	Washer
49	35P041	Spring Washer
50	35P048	Screw
51	35P049	Spring Pin
52	35P050	Screw
53	35P051	Trigger Screw
55	35P052	Spring Pin
56	35P053	Teeth Washer
57	35P054	Screw
58	35P066	Spring Pin
59	35P056	O-Ring
61	35P058	O-Ring
62	35P059	O-Ring
63	35P060	O-Ring
64	35P061	O-Ring
65	35P062	Rod
66	35P063	Screw
67	35P064	Screw
68	35P065	Spring Washer
69	35P066	Spring Pin
70	32P570	Screw
71	35P069	Screw
72	35P070	Pin
73	35P071	Pin
74	35M046N	Screw
75	35P072	Spring Pin
76	35P076	Lock Nut
77	32P577	Screw
78	32M549	Spring Pin
79	35P081	E-Ring
80	35P080N	C-Ring
81	35P084	Heli-Coil
82	35P085	Plastic Pin
83	19B091	Counter Balance Hanger
85	32P585	Screw
86	35M321	Magazine Ass'y

### COME CARICARE LE GRAFFE

- 1 - Togliere l'alimentazione.
- 2 - Tirare lo spingipunto (32) fino alla fine del caricatore (29). Farlo quindi ruotare verso il basso fino a toccare la parte inferiore del caricatore.
- 3 - Inserire le graffe in modo corretto nel caricatore a partire dalla parte posteriore.
- 4 - Alzare lo spingipunto e farlo scorrere contro le graffe.

### HOW LOADING THE STAPLES

- 1 - Disconnect the air pressure.
- 2 - Pull the pusher (32) back to the end of the magazine (29) and turn the pusher downward until reaching the bottom of the magazine.
- 3 - Insert the staples into the magazine from the rear to the front.
- 4 - Turn the pusher upward and release it against the staples.

### REGOLAZIONE IN BASE ALLA LUNGHEZZA DELLA GRAFFA

- 1 - Togliere l'alimentazione.
- 2 - Allentare il grano (66).
- 3 - Girare la vite (18) posizionandola con la "S" in alto graffe corte o con la "L" in alto per graffe lunghe.
- 4 - Stringere di nuovo il grano (66).

### HOW SETTING THE LENGTH OF THE STAPLE LEGS

- 1 - Disconnect the air pressure.
- 2 - Screw off bolt (66).
- 3 - Turn the adjusting rod (18) to put "S" up for shorter staples and to put "L" up for longer ones.
- 4 - Tighten bolt (66).

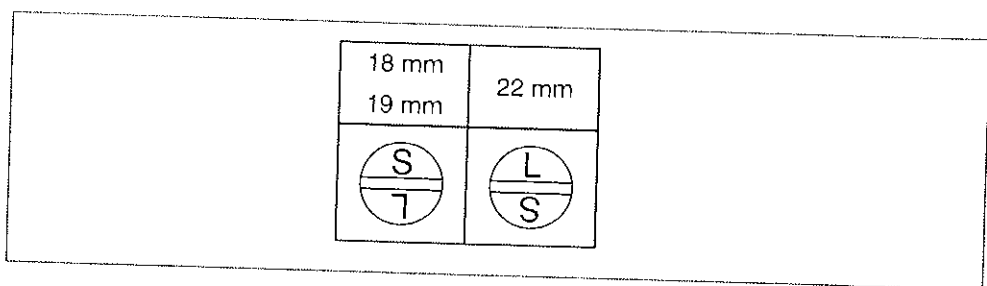

### COME ADDATTARE

#### A. Profondita'

- 1 - Togliere l'alimentazione.
- 2 - Allentare la vite (67).
- 3 - Far scorrere la piastra frontale (20) verso l'alto o il basso e posizionare la piastra di regolazione (19) su una delle tacche da 1 a 4 a seconda della maggiore o minore profondita' desiderata. (Vedi Fig. 2)

### HOW TO ADJUST

#### A. Depth

- 1 - Disconnect the air pressure.
- 2 - Screw off bolt (67).
- 3 - Slide front plate (20) up or down and set the top of the adjusting plate (19) on position no. 1 for deepest penetration and no. 4 for the shallow one (See picture no. 2)

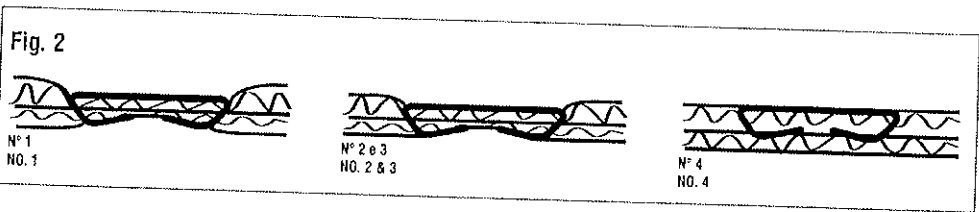

#### B. Chiusura

- 1 - Girare il collare (6) con un perno in senso orario per una maggiore ribaditura e in senso antiorario in caso contrario. (Vedi Fig. 3)

#### B. Clinching

- 1 - Turn collar (6) with a stick through the window, clockwise for a tight clinch and counterclockwise for a loose clinch. (See picture Fig. 3)

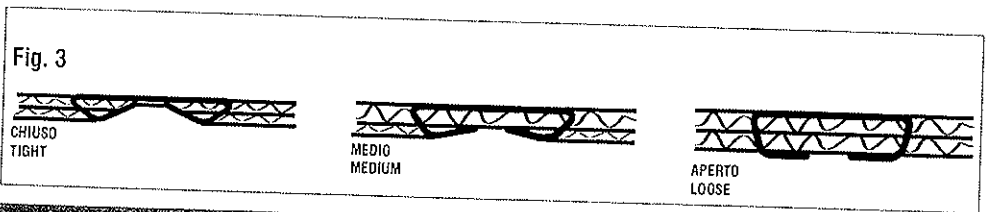

1971873\_3522\_190413 IV

35.22

cod. 19822T3

Indice di modifica Upgrade number 3

301758