



Manuale d'uso, manutenzione e parti di ricambio	Parte 2
Use, maintenance and spare parts manual	Part 2
Gebrauchsanweisung, Instandhaltungsrichtlinien und Ersatzteile	Teil 2
Manuel d'utilisation, entretien et pièces de rechange	Partie 2
Manual de uso, mantenimiento y repuestos	Part 2
Manual de utilização, manutenção e partes sobresselentes	Parte 2
Handleiding voor gebruik, onderhoud en reservedelslste	Deel 2
Brugsanvisning, vedligeholdelse og reservedelslste	Del 2



3G.16

cod. 1144300



1144300_3G16_6 100510 IV

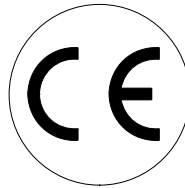

Dati tecnici Technical data Technische daten	Données techniques Datos tècnics	Dados tècnics Technischegegevens Teknische data
Misure impiegabili mm Usable lengths mm Gebrauchliche Längen mm	Mesures utilisable mm Medidas que se pueden emplear mm	Medidas que se podem utilizar mm Te gebruiken engtes in mm Brugbare laengder i mm
Capacità caricatore n° punti Magazine capacity No. of fasteners Magazinkapazität Nägel	Capacité chargeur n° de points Capacidad cargador n° puntos	Capacidade carregador n° pontos Capaciteit magazijn in aantal spijkers Kapacitet af magasin antal klemme
Pressione d'esercizio Working pressure Betriebsdruck	Pression de fonctionnement Presión de trabajo	Pressao de trabalho Werkdruk Arbejds tryk bar
Consumo aria litri/colpo Air consumption litres/shot Luftverbrauch Liter/Schlag	Consommation air litre/coup Consumo aire-litros/golpe	Consumo ar litro/golpe Luchtverbruik liter/schot Luftforbrug liter/skud
Peso kg Weight kg Gewicht kg	Poids kg Peso kg	Peso kg Gewicht in kg Vaegt kg
Dimensioni (AxBxH) mm Dimensions mm Größe mm	Dimension mm Dimensiones mm	Dimencoes mm Afmetingen in mm Dimensioner mm
EN 12549 :1999 ISO 11201 :1995		
Pressione sonora in pos. operatore Sound pressure at the workstation Lärmintensität am Arbeitsplatz	Pression acoustique près de l'opérateur Presión sonora en posición encargado	Intensidade sonora perto do operador Geluidssterkte op de werkplek Lydstyrke på operatorposten
EN 12549 :1999 ISO 3744 :1994		
Potenza sonora emessa Emitted sound power Ausgestrahlte Lärmintensität	Puissance acoustique émise Potencia sonora emitida	Potência sonora emitida Uitgestraalde geluidssterkte Udsendt lydstryrke
EN 28662 :1992 ISO 5349 :1986 ISO 8662 -11		
Valore medio ponderato di vibrazione sull'impugnatura max.33 colpi Weighted mean value of vibration on the grip max.33 shots Mittlerer Vibrationswert, am Griff gemessen max.33 Schläge	Valeur moyenne pondérée de vibration mesurée sur la poignée max.33 coups Valor medio ponderado de vibracion medida en la empuñadura max.33 golp	Valor medio ponderado de vibracao medida no punho max.33 golpes Gewogen gemiddelde vibratiewaarde max.33 schot Middelvaerdi af vibrationer pa handtaget max.33 skud

Tipo di punto
Type of fastener
Befestigungselement
Type d'agrafe
Tipo de punto

Tipo de ponto
Type nietjes
Tilspændingstype

3G

0,55x0,75

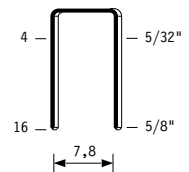

Crown: .350" (3/8")
Thickness: .022"
Width: .030"
Gauge: 23

Parti di ricambio - Spare parts - Ersatzteile - Pièces de rechange - Piezas de repuesto
 - Partes sobresselentes - Tabel te raadplegen - Reservedele

Cod.	Descrizione	Description
00.06	O-Ring	O-Ring
00.12	O-Ring	O-Ring
00.13	O-Ring	O-Ring
00.14	O-Ring	O-Ring
00.26	O-Ring	O-Ring
00.27	O-Ring	O-Ring
00.35	O-Ring	O-Ring
01.21.1	Guarnizione	Gasket
01.21.3	Guarnizione	Gasket
01.29	O-Ring	O-Ring
01.33	O-Ring	O-Ring
04.06.5	Vite	Screw
04.10	Vite	Screw
04.12	Vite	Screw
04.16	Vite	Screw
04.20	Vite	Screw
04.35	Vite	Screw
07.05	Sfera	Ball
07.30	Chiave esagonale	Hex. bar wrench
09.02	Anello elastico	Elastic ring
14.18.1	Spina	Pin
20.00	Corpo	Body
22.00	Testa	Head
24.00	Silenziatore	Silencer
25.04	Deflettore	Exhaust deflector
26.07	Cilindro	Cylinder
28.00	Guarnizione	Gasket
30.07.3	Pistone	Piston
32.05	Ammortizzatore	Bumper
39.00	Guarnizione scarico	Exhaust gasket
40.04.2	Valvola completa	Valve ass'y
45.04	Anello valvola	Ring
54.03	Pulsante	Trigger valve
55.06	Raccordo	Bush
70.04	Protezione	Guard
72.03.3	Reggicaricatore	Support
76.04	Perno	Pin
76.14	Perno	Pin
76.45	Perno molla	Pin
80.08	Grilletto chiusura	Trigger
81.09	Grilletto comando	Trigger
81.15	Controgrilletto	Safety
90.07	Molla	Spring
90.10	Molla	Spring
91.03X	Molla	Spring
92.01X	Molla	Spring
93.02	Molla	Spring
22.00.43	Battente	Driver
53.00.43	Caricatore	Magazine
62.00.43	Carrello	Slider
70.00.43	Spingipunto	Pusher
81.00.80	Controtestina	Nose
91.00.43	Testina	Nose plate

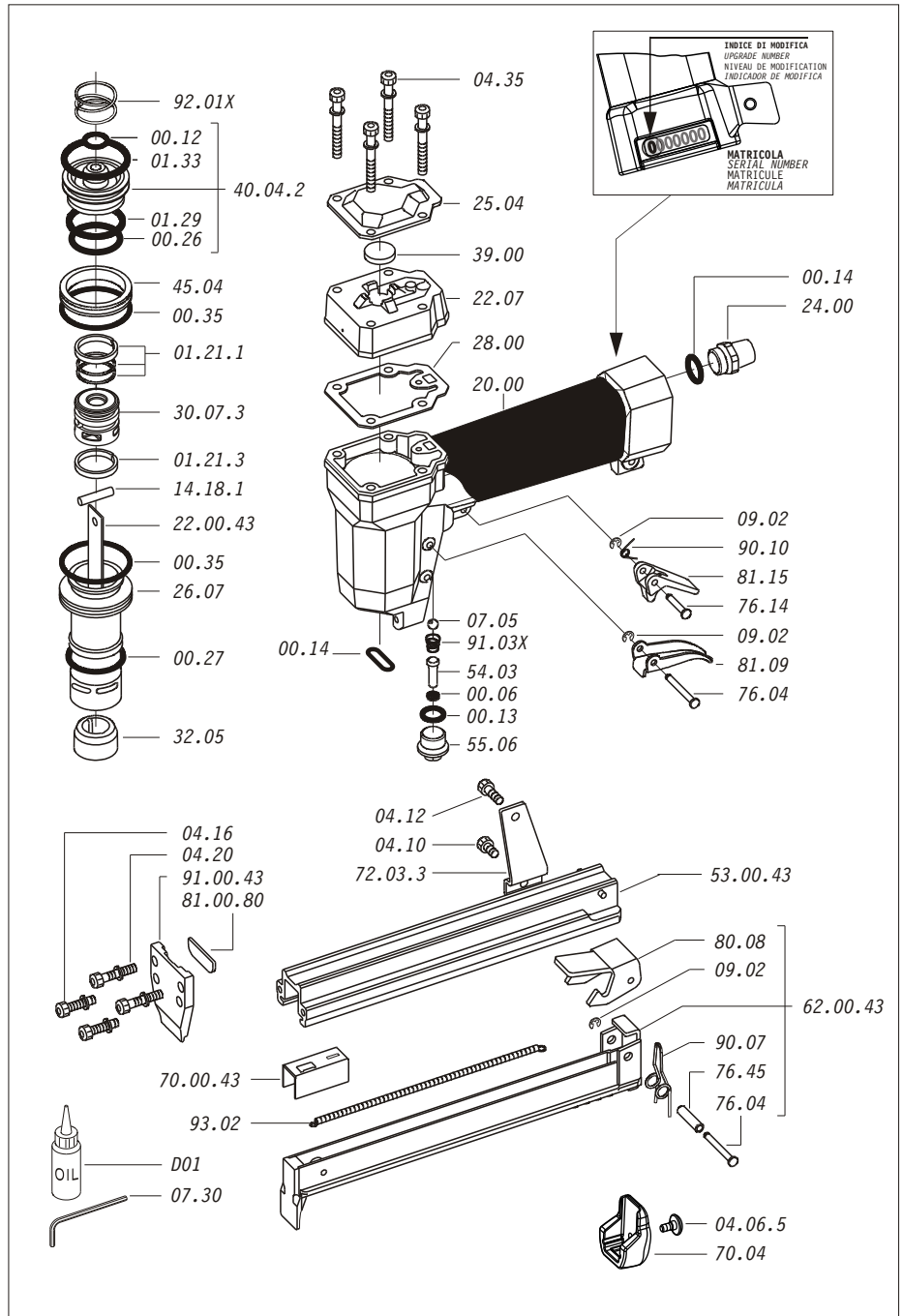

Guarnizioni - O-Rings - Dichtungen - Joints - Kit O-Rings -

- Kit O-Rings - O-ringen - Pakninger

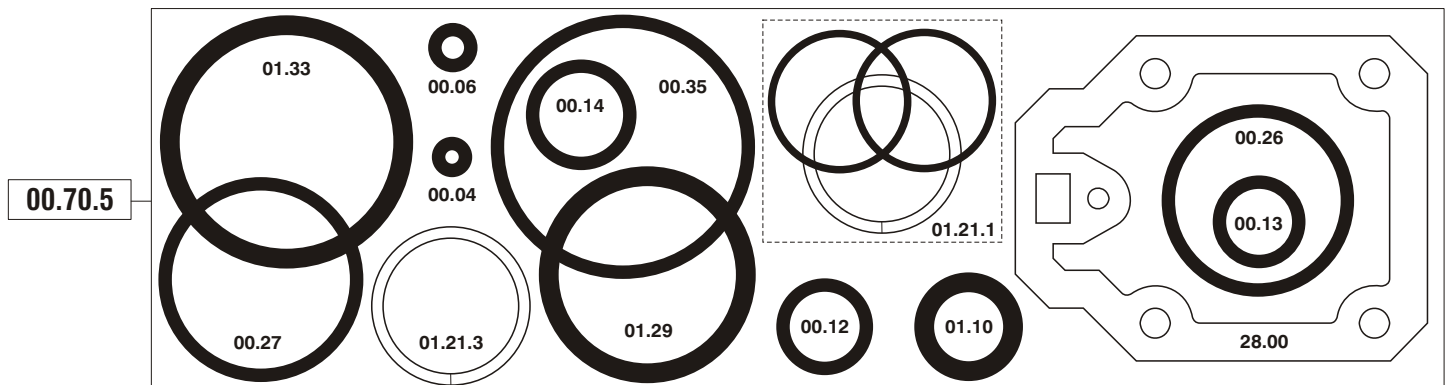

1144300_3G16_6 100510 IV

3G.16

cod. 1144300

Indice di modifica
Upgrade number

6

6019194