

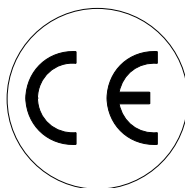

<b>Manuale d'uso, manutenzione e parti di ricambio</b>	<b>Parte 2</b>
<b>Use, maintenance and spare parts manual</b>	<b>Part 2</b>
<b>Gebrauchsanweisung, Instandhaltungsrichtlinien und Ersatzteile</b>	<b>Teil 2</b>
<b>Manuel d'utilisation, entretien et pièces de rechange</b>	<b>Partie 2</b>
<b>Manual de uso, mantenimiento y repuestos</b>	<b>Part 2</b>
<b>Manual de utilização, manutenção e partes sobresselentes</b>	<b>Parte 2</b>
<b>Handleiding voor gebruik, onderhoud en reservedelslste</b>	<b>Deel 2</b>
<b>Brugsanvisning, vedligeholdelse og reservedelslste</b>	<b>Del 2</b>



1143550\_5516CLM\_6 100510 IV



# 55.16 CLM

cod. 1143550

<b>Dati tecnici</b> Technical data Technische daten	<b>Données techniques</b> Datos tècnicos	<b>Dados tècnicos</b> Technischegegevens Tehniske data
<b>Misure impiegabili mm</b> Usable lengths mm Gebrauchliche Längen mm	Mesures utilisable mm Medidas que se pueden emplear mm	Medidas que se podem utilizar mm Te gebruiken engtes in mm Brugbare laengder i mm
<b>Capacità caricatore n° punti</b> Magazine capacity No. of fasteners Magazinkapazität Nägel	Capacité chargeur n° de points Capacidad cargador n° puntos	Capacidade carregador n° pontos Capaciteit magazijn in aantal spijkers Kapacitet af magasin antal klemme
<b>Pressione d'esercizio</b> Working pressure Betriebsdruck	Pression de fonctionnement Presión de trabajo	Pressao de trabalho Werkdruk Arbejds tryk bar
<b>Consumo aria litri/colpo</b> Air consumption litres/shot Luftverbrauch Liter/Schlag	Consommation air litre/coup Consumo aire-litros/golpe	Consumo ar litro/golpe Luchtverbruik liter/schot Luftforbrug liter/skud
<b>Peso kg</b> Weight kg Gewicht kg	Poids kg Peso kg	Peso kg Gewicht in kg Vaegt kg
<b>Dimensioni (AxBxH) mm</b> Dimensions mm Größe mm	Dimension mm Dimensiones mm	Dimencoes mm Afmetingen in mm Dimensioner mm
<b>EN 12549 :1999 ISO 11201 :1995</b>		
<b>Pressione sonora in pos. operatore</b> Sound pressure at the workstation Lärmintensität am Arbeitsplatz	Pression acoustique près de l'opérateur Presión sonora en posición encargado	Intensidade sonora perto do operador Geluidssterkte op de werkplek Lydstyrke på operatorposten
<b>EN 12549 :1999 ISO 3744 :1994</b>		
<b>Potenza sonora emessa</b> Emitted sound power Ausgestrahlte Lärmintensität	Puissance acoustique émise Potencia sonora emitida	Potência sonora emitida Uitgestraalde geluidssterkte Udsendt lydstryrke
<b>EN 28662 :1992 ISO 5349 :1986 ISO 8662 -11</b>		
<b>Valore medio ponderato di vibrazione sull'impugnatura max.33 colpi</b> Weighted mean value of vibration on the grip max.33 shots Mittlerer Vibrationswert, am Griff gemessen max.33 Schläge	Valeur moyenne pondérée de vibration mesurée sur la poignée max.33 coups Valor medio ponderado de vibracion medida en la empuñadura max.33 golp	Valor medio ponderado de vibracao medida no punho max.33 golpes Gewogen gemiddelde vibratiewaarde max.33 schot Middelvaerdi af vibrationer pa handtaget max.33 skud

**Tipo di punto**  
Type of fastener  
Befestigungselement  
Type d'agrafe  
Tipo de punto  
  
Tipo de ponto  
Type nietjes  
Tilspændingstype

**55**

0.50x1.25

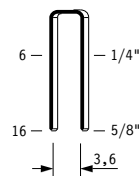

Crown: .181" (3/16")  
Thickness: .020"  
Width: .050"  
Gauge: 19

Parti di ricambio - Spare parts - Ersatzteile - Pièces de rechange - Piezas de repuesto  
 - Partes sobresselentes - Tabel te raadplegen - Reservedele

Cod.	Descrizione	Description
00.06	O-Ring	O-Ring
00.12	O-Ring	O-Ring
00.13	O-Ring	O-Ring
00.14	O-Ring	O-Ring
00.26	O-Ring	O-Ring
00.27	O-Ring	O-Ring
00.35	O-Ring	O-Ring
01.21.1	Guarnizione	Gasket
01.21.3	Guarnizione	Gasket
01.29	O-Ring	O-Ring
01.33	O-Ring	O-Ring
04.10	Vite	Screw
04.12	Vite	Screw
04.16	Vite	Screw
04.18	Vite	Screw
04.25	Vite	Screw
04.35	Vite	Screw
07.05	Sfera	Ball
07.30	Chiave esagonale	Hex. bar wrench
09.02	Anello elastico	Elastic ring
14.18.1	Spina	Pin
20.00	Corpo	Body
22.07	Testa	Head
24.00	Silenziatore	Silencer
25.04	Deflettore	Exhaust deflector
26.07	Cilindro	Cylinder
28.00	Guarnizione	Gasket
30.07.3	Pistone	Piston
32.05	Ammortizzatore	Bumper
39.00	Guarnizione scarico	Exhaust gasket
40.04.2	Valvola completa	Valve ass'y
45.04	Anello valvola	Ring
54.03	Pulsante	Trigger valve
55.06	Raccordo	Bush
64.05	Carter	Hold down
72.03.4	Reggicaricatore	Support
73.00	Perno	Pin
75.03	Tastatore	Actuator
76.04	Perno	Pin
76.15	Perno	Pin
77.03	Guida tastatore	Actuator guide
80.09	Grilletto chiusura	Trigger
81.77.1	Leva rinvio	Trigger lever
91.03X	Molla	Spring
91.05	Molla	Spring
91.07	Molla	Spring
92.01X	Molla	Spring
93.07	Molla	Spring
22.00.55	Battente	Driver
52.05.40	Caricatore	Magazine
62.05.55	Carrello	Slider
72.05.55	Spingipunto	Pusher
81.00.80	Controtestina	Nose
92.05.55	Testina	Nose plate
D01	Bocchetta olio	Oiler

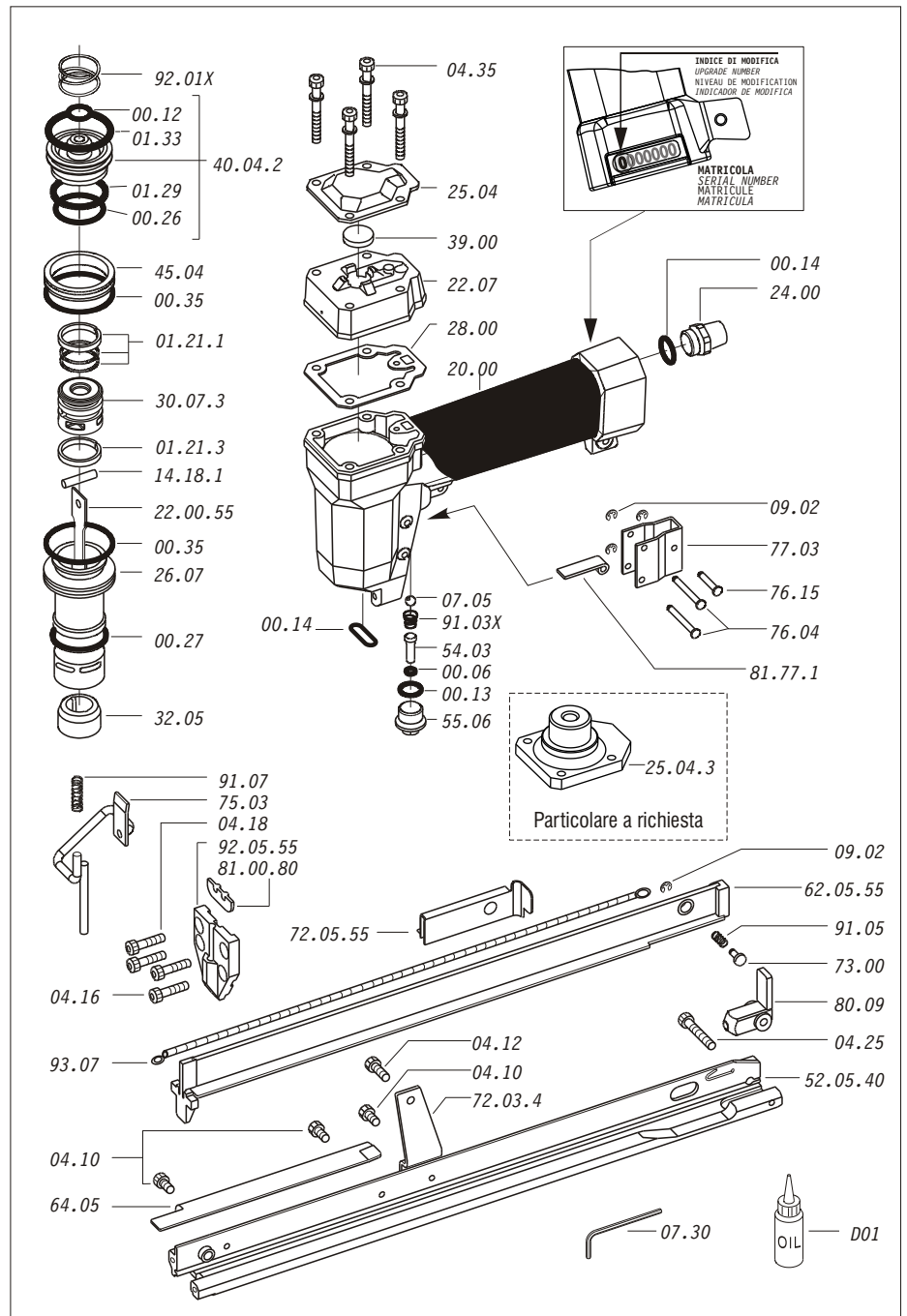

Guarnizioni - O-Rings - Dichtungen - Joints - Empaquetadura de anillo -

- Kit de o-rings - O-ringen - Pakninger

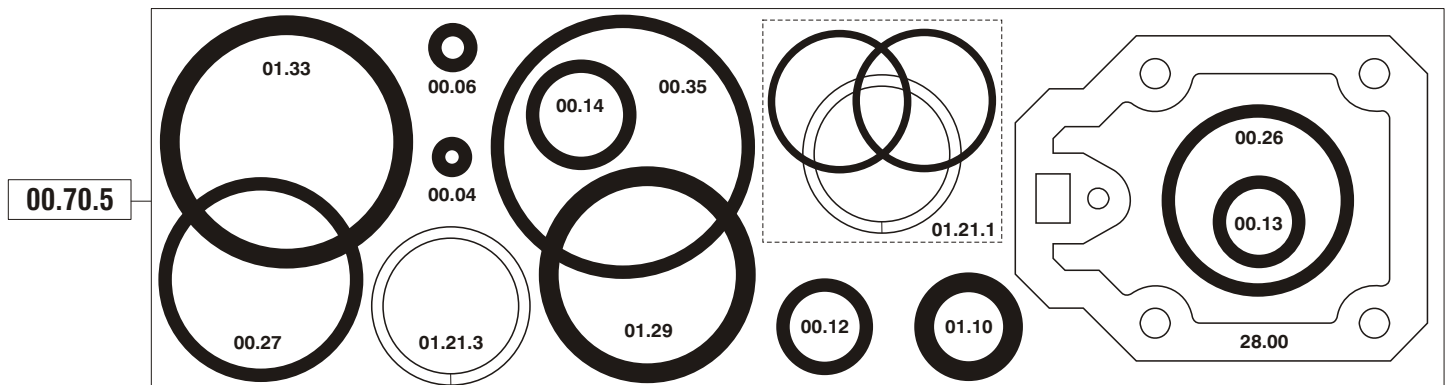

55.16 CLM

cod. 1143550

Indice di modifica  
 Upgrade number

6

6019800