

Caratteristiche - Features

Disinceppamento macchina Quick clearance jammed nails

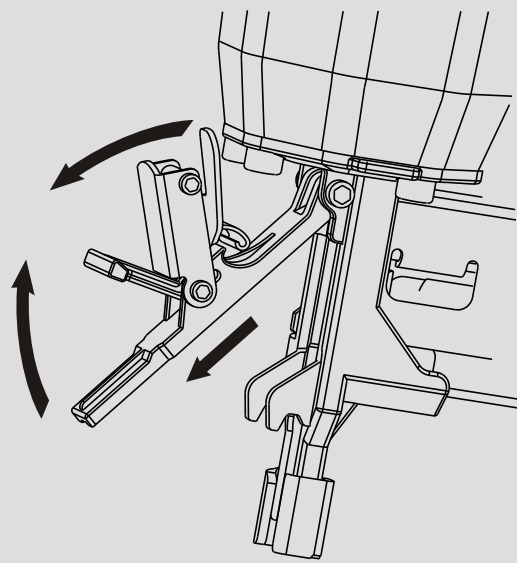

Colpo martello Bump fire

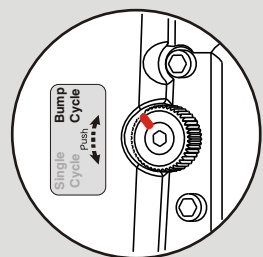
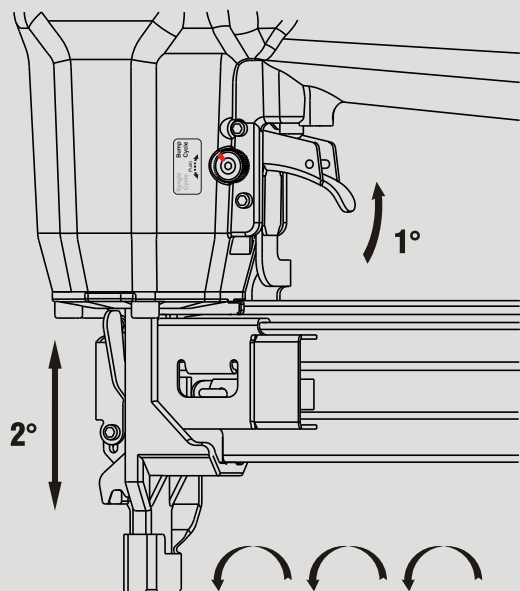

Colpo singolo Sequential fire

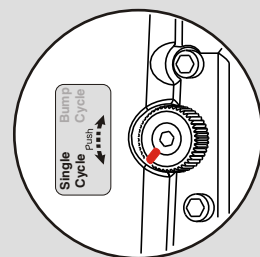
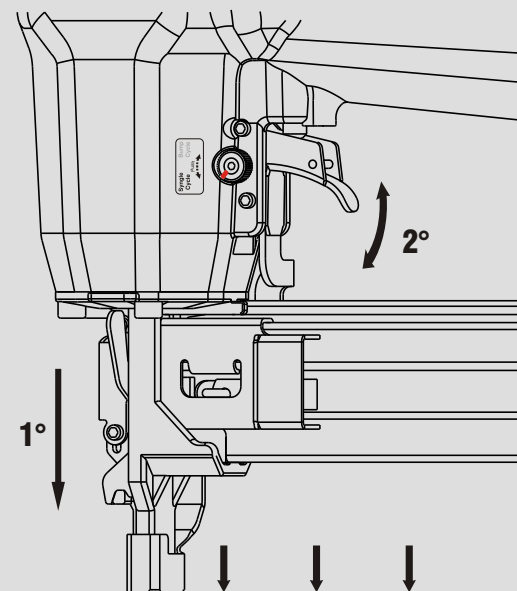

OMER

Manuale d'uso, manutenzione e parti di ricambio **Parte 2**
Use, maintenance and spare parts manual **Part 2**
Gebrauchsanweisung, Instandhaltungsrichtlinien und Ersatzteile **Teil 2**
Manuel d'utilisation, entretien et pièces de rechange **Partie 2**
Manual de uso, mantenimiento y repuestos **Part 2**

Manual de utilização, manutenção e partes sobresselentes **Parte 2**
Handleiding voor gebruik, onderhoud en reservedelslste **Deel 2**
Brugsanvisning, vedligeholdelse og reservedelslste **Del 2**



M2.50

cod. 1818200

1818200_M250_1 130605 DVM

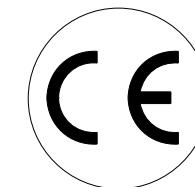

Dati tecnici Technical data Technische daten	Données techniques Datos técnicos	Dados técnicos Technischegegevens Tekniske data
Misure impiegabili mm Usable lengths mm Gebrauchliche Längen mm	Mesures utilisable mm Medidas que se pueden emplear mm	Medidas que se podem utilizar mm Te gebruiken engtes in mm Brugbare laengder i mm
Capacità caricatore n° punti Magazine capacity No. of fasteners Magazinkapazität Nägel	Capacité chargeur n° de points Capacidad cargador n° puntos	Capacidade carregador n° pontos Capaciteit magazijn in aantal spijkers Kapacitet af magasin antal klemme
Pressione d'esercizio Working pressure Betriebsdruck	Pression de fonctionnement Presión de trabajo	Pressao de trabalho Werkdruk Arbejds tryk bar
Consumo aria litri/colpo Air consumption litres/shot Luftverbrauch Liter/Schlag	Consommation air litre/coup Consumo aire-litros/golpe	Consumo ar litro/golpe Luchtverbruik liter/schot Luftforbrug liter/skud
Peso kg Weight kg Gewicht kg	Poids kg Peso kg	Peso kg Gewicht in kg Vægt kg
Dimensioni (AxBxH) mm Dimensions mm Größe mm	Dimension mm Dimensiones mm	Dimencoes mm Afmetingen in mm Dimensioner mm
ISO 11201 Pressione sonora in pos. operatore Sound pressure at the workstation Lärmintensität am Arbeitsplatz	ISO 11201 Pression acoustique près de l'opérateur Presión sonora en posición encargado	ISO 11201 Intensidade sonora perto do operador Geluidssterkte op de werkplek Lydstyrke på operatorposten
ISO 3744 Potenza sonora emessa Emitted sound power Ausgestrahlte Lärmintensität	ISO 3744 Puissance acoustique émise Potencia sonora emitida	ISO 3744 Potência sonora emitida Uitgestraalde geluidssterkte Udsendt lydstryke
ISO 5349-86 Valore medio ponderato di vibrazione sull'impugnatura max.33 colpi Weighted mean value of vibration on the grip max.33 shots Mittlerer Vibrationswert, am Griff gemessen max.33 Schäge	ISO 5349-86 Valeur moyenne pondérée de vibration mesurée sur la poignée max.33 coups Valor medio ponderado de vibracion medida en la empuñadura max.33 gomp	ISO 5349-86 Valor medio ponderado de vibracao medida no punho max.33 golpes Gewogen gemiddelde vibratiowaarde max.33 schot Middelvaerdi af vibrationer pa handtaget max.33 skud

Tipo di punto
Type of fastener
Befestigungselement
Type d'agrafe
Tipo de punto
Tipo de ponto
Type nietjes
Tilspændingstype

M2

1,40x1,60

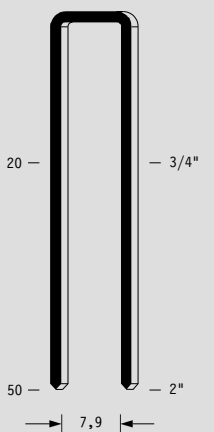

Gauge: 16
Crown: .420" (7/16")

Parti di ricambio - Spare parts - Ersatzteile - Pièces de rechange - Piezas de repuesto
- Partes sobresselentes - Tabel te raadplegen - Reservedele

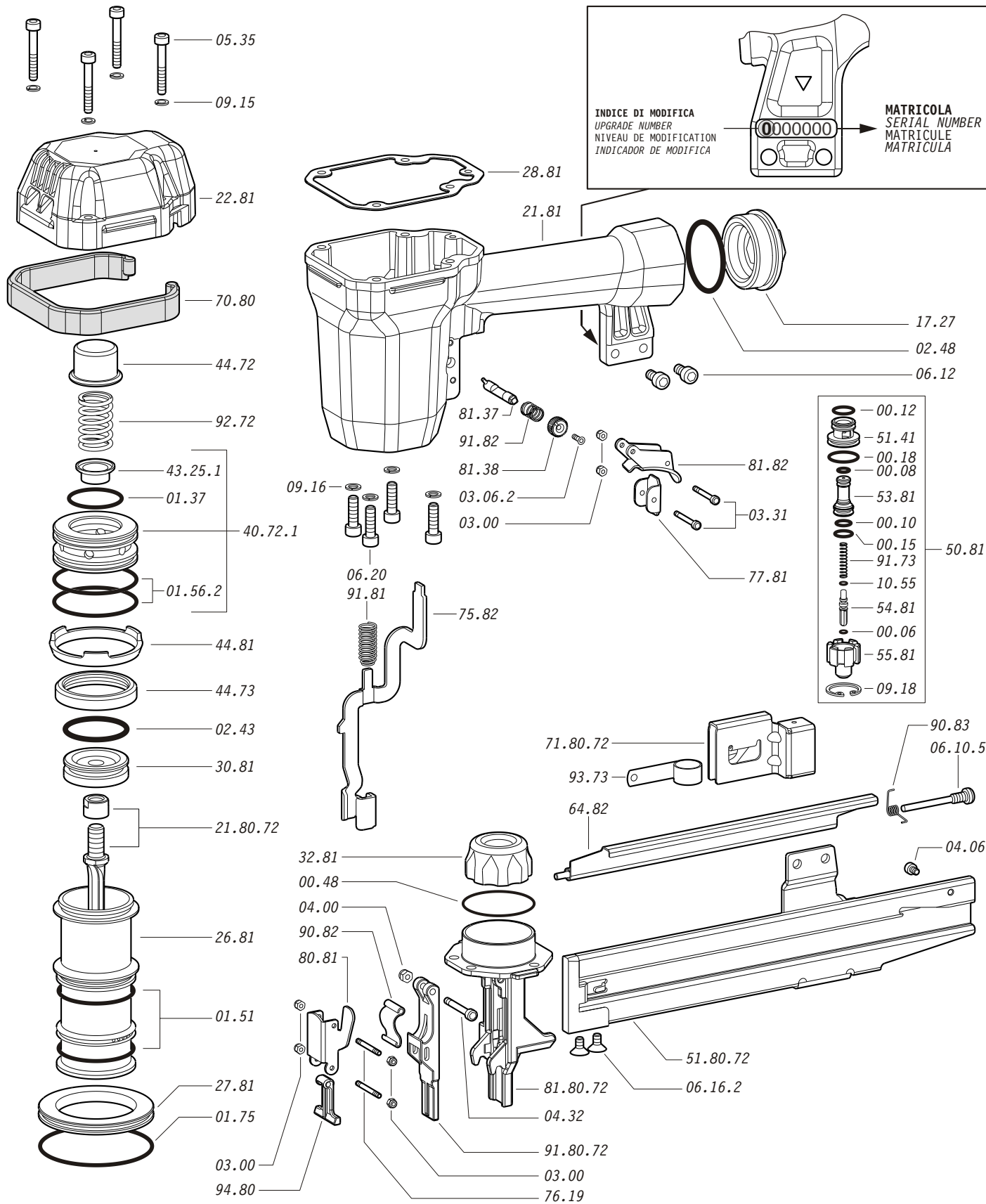

Dotazioni - Equipment - Ausrüstung - Équipements - Equipamiento -

Equipamento - Uitrusting - Udstyr

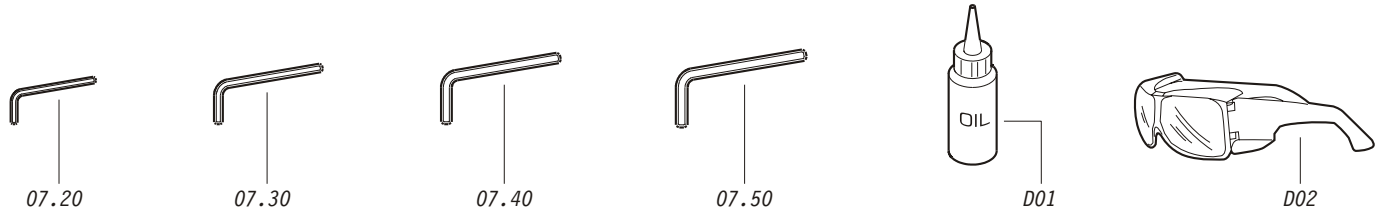

Parti di ricambio - Spare parts - Ersatzteile - Pièces de rechange - Piezas de repuesto
- Partes sobresselentes - Tabel te raadplegen - Reservedele

Cod.	Descrizione	Description
00.06	O-Ring	O-Ring
00.08	O-Ring	O-Ring
00.10	O-Ring	O-Ring
00.12	O-Ring	O-Ring
00.15	O-Ring	O-Ring
00.18	O-Ring	O-Ring
00.48	O-Ring	O-Ring
01.37	O-Ring	O-Ring
01.51	O-Ring	O-Ring
01.56.2	O-Ring	O-Ring
01.75	O-Ring	O-Ring
02.43	O-Ring	O-Ring
02.48	O-Ring	O-Ring
03.00	Dado	Nut
03.06.2	Vite	Screw
03.31	Vite	Screw
04.00	Dado	Nut
04.32	Vite	Screw
04.06	Vite	Screw
05.35	Vite	Screw
06.10.5	Vite	Screw
06.12	Vite	Screw
06.16.2	Vite	Screw
06.20	Vite	Screw
07.20	Chiave esagonale	Hex. bar wrench
07.30	Chiave esagonale	Hex. bar wrench
07.40	Chiave esagonale	Hex. bar wrench
07.50	Chiave esagonale	Hex. bar wrench
09.15	Rondella	Washer
09.16	Rondella	Washer
09.18	Anello elastico	Elastic ring
10.55	O-Ring	O-Ring
17.27	Tappo	Inlet cap
21.81	Corpo	Body
22.81	Testa	Head
26.81	Cilindro	Cylinder
27.81	Anello cilindro	Cylinder ring
28.81	Guarnizione testa	Head gasket
30.81	Pistone	Piston
32.81	Ammortizzatore	Bumper
40.72.1	Valvola completa	Valve ass'y
43.25.1	Rondella porta molla	Spring support washer
44.72	Ammortizzatore	Bumper
44.73	Guarnizione cilindro	Cylinder gasket
44.81	Distanziale	Spacer
50.81	Pulsante completo	Trigger valve ass'y
51.41	Boccola pulsante	Trigger valve housing
53.81	Pistone servovalvola	Valve piston
54.81	Pulsante	Trigger valve
55.81	Raccordo pulsante	Bush
64.82	Carter	Hold down
70.80	Protezione	Guard
75.82	Sicura	Safety
76.19	Perno	Pin
77.81	Guida sicura	Safety guide
80.81	Grilletto testina	Nose plate lock
81.37	Perno selettore	Selecting pin
81.38	Pomello	Knob
81.82	Grilletto comando	Trigger
90.82	Molla	Spring
90.83	Molla	Spring
91.81	Molla	Spring
91.82	Molla	Spring
91.73	Molla	Spring
92.72	Molla	Spring
93.73	Molla	Spring
94.80	Tirante	Connecting rod
21.80.72	Battente	Driver
51.80.72	Caricatore	Magazine
71.80.72	Spingipunto	Pusher
81.80.72	Controtestina	Nose
91.80.72	Testina	Nose plate
D01	Bocchetta olio	Oiler
D02	Occhiali protettivi	Protective goggles

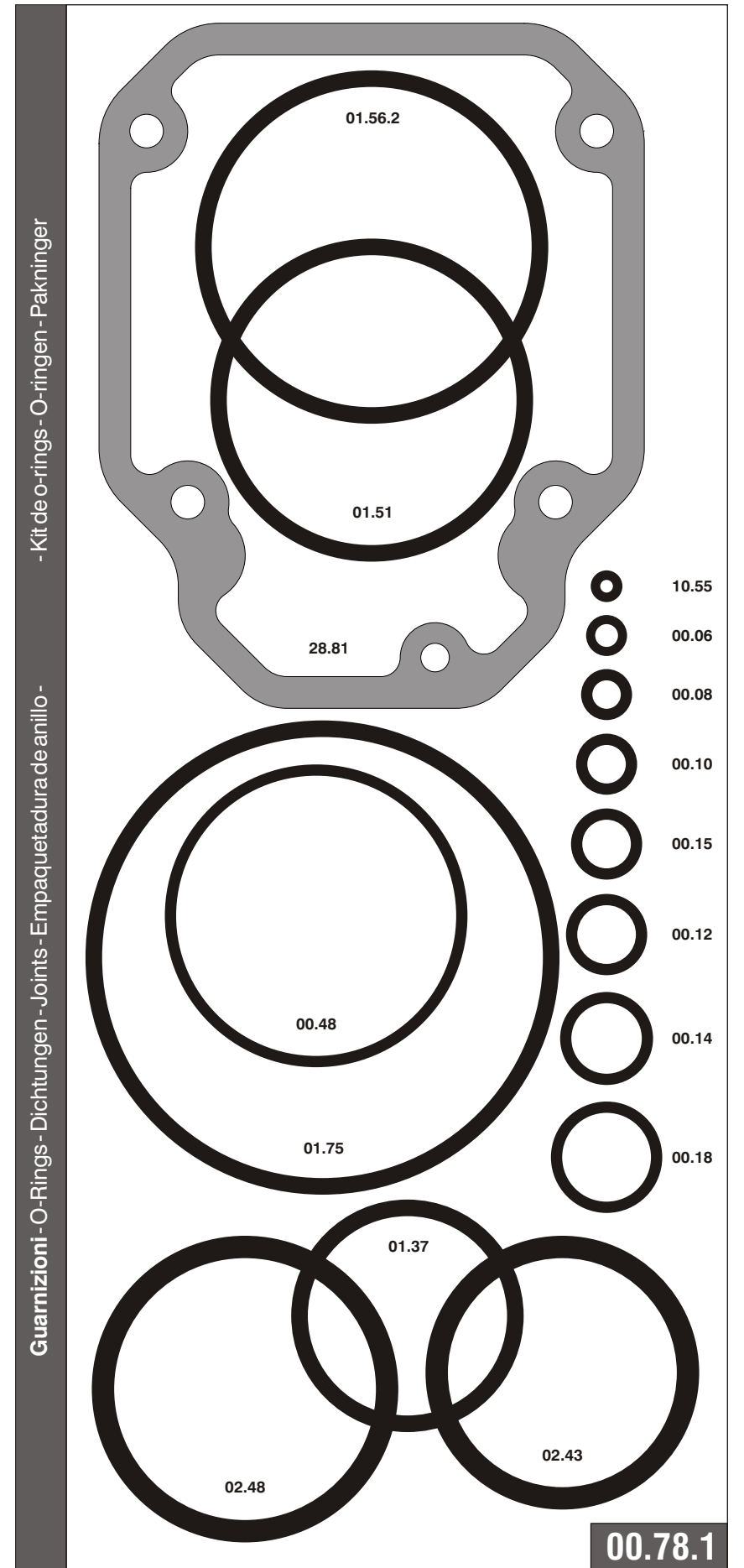

- Kit de o-rings - O-ringen - Pakninger

- Guarnizioni - O-Rings - Dichtungen - Joints - Empaquetadura de anillo -

00.78.1

1818200_M250_1_130605

M2.50

cod. 1818200

Indice di modifica
Upgrade number

1

10880502