

Römer



Manuale d'uso, manutenzione e parti di ricambio	Parte 2
Use, maintenance and spare parts manual	Part 2
Gebrauchsanweisung, Instandhaltungsrichtlinien und Ersatzteile	Teil 2
Manuel d'utilisation, entretien et pièces de rechange	Partie 2
Manual de uso, mantenimiento y repuestos	Part 2
Manual de utilização, manutenção e partes sobresselentes	Parte 2
Handleiding voor gebruik, onderhoud en reservedelslste	Deel 2
Brugsanvisning, vedligeholdelse og reservedelslste	Del 2

mignon 26

cod. 1055020

1055020_mignon26_2 091110 IV

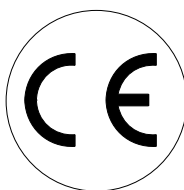

Dati tecnici Technical data Technische daten	Données techniques Datos tècnicos	Dados tècnicos Technischegegevens Teknische data	
Misure impiegabili mm Usable lengths mm Gebrauchliche Längen mm	Mesures utilisable mm Medidas que se pueden emplear mm	Medidas que se podem utilizar mm Te gebruiken engtes in mm Brugbare laengder i mm	6 ÷ 8
Capacità caricatore n° punti Magazine capacity No. of fasteners Magazinkapazität Nägel	Capacité chargeur n° de points Capacidad cargador n° puntos	Capacidade carregador n° pontos Capaciteit magazijn in aantal spijkers Kapacitet af magasin antal klemme	260
Pressione d'esercizio Working pressure Betriebsdruck	Pression de fonctionnement Presión de trabajo	Pressao de trabalho Werkdruk Arbejds tryk bar	4 ÷ 4,5 bar 60 ÷ 65 psi
Consumo aria litri/colpo Air consumption litres/shot Luftverbrauch Liter/Schlag	Consommation air litre/coup Consumo aire-litros/golpe	Consumo ar litro/golpe Luchtverbruik liter/schot Luftforbrug liter/skud	0,10
Peso kg Weight kg Gewicht kg	Poids kg Peso kg	Peso kg Gewicht in kg Vaegt kg	0,76
Dimensioni (AxBxH) mm Dimensions mm Größe mm	Dimension mm Dimensiones mm	Dimencoes mm Afmetingen in mm Dimensioner mm	189x40x144
EN 12549 :1999 ISO 11201 :1995			
Pressione sonora in pos. operatore Sound pressure at the workstation Lärmintensität am Arbeitsplatz	Pression acoustique près de l'opérateur Presión sonora en posición encargado	Intensidade sonora perto do operador Geluidssterkte op de werkplek Lydstyrke på operatorposten	76,7 dB(A)
EN 12549 :1999 ISO 3744 :1994			
Potenza sonora emessa Emitted sound power Ausgestrahlte Lärmintensität	Puissance acoustique émise Potencia sonora emitida	Potência sonora emitida Uitgestraalde geluidssterkte Udsendt lydstyrke	82,2 dB(A)
EN 28662 :1992 ISO 5349 :1986 ISO 8662 -11			
Valore medio ponderato di vibrazione sull'impugnatura max.33 colpi Weighted mean value of vibration on the grip max.33 shots Mittlerer Vibrationswert, am Griff gemessen max.33 Schläge	Valeur moyenne pondérée de vibration mesurée sur la poignée max.33 coups Valor medio ponderado de vibracion medida en la empuñadura max.33 golp	Valor medio ponderado de vibracao medida no punho max.33 golpes Gewogen gemiddelde vibratiewaarde max.33 schot Middelvaerdi af vibrationer pa handtaget max.33 skud	<2,5 m/s²

Tipo di punto
Type of fastener
Befestigungselement
Type d'agrafe
Tipo de punto
Tipo de ponto
Type nietjes
Tilspændingstype

26

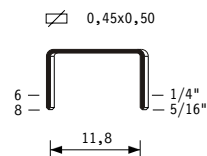

Gauge: 25½
Crown: .503" (1/2")

Parti di ricambio - Spare parts - Ersatzteile - Pièces de rechange - Piezas de repuesto
 - Partes sobresselentes - Tabel te raadplegen - Reservedele

Cod.	Descrizione	Description
00.06	O-Ring	O-Ring
00.09	O-Ring	O-Ring
00.14	O-Ring	O-Ring
00.18	O-Ring	O-Ring
00.22	O-Ring	O-Ring
01.33	O-Ring	O-Ring
02.26	O-Ring	O-Ring
04.08	Vite	Screw
04.12	Vite	Screw
04.14	Vite	Screw
07.30	Chiave esagonale	Hex. bar wrench
13.22	Spina	Pin
21.12.7	Corpo	Body
22.10N	Deflettore	Exhaust deflector
30.11	Pistone	Piston
32.10	Ammortizzatore	Bumper
39.10	Guarnizione scarico	Exhaust gasket
41.10	Pistone valvola	Valve piston
45.10	Anello valvola	Valve ring
54.10	Pulsante	Trigger valve
55.10	Raccordo	Bush
71.11N	Reggicaricatore	Support
81.10N	Grilletto comando	Trigger
91.00	Molla	Spring
92.00	Molla	Spring
93.02	Molla	Spring
22.00.78	Battente	Driver
52.10.78	Caricatore	Magazine
62.10.78	Carrello	Slider
70.10.78	Spingipunto	Pusher
80.10.78	Controtestina	Nose
90.10.78	Testina	Nose plate
D01	Bocchetta olio	Oiler

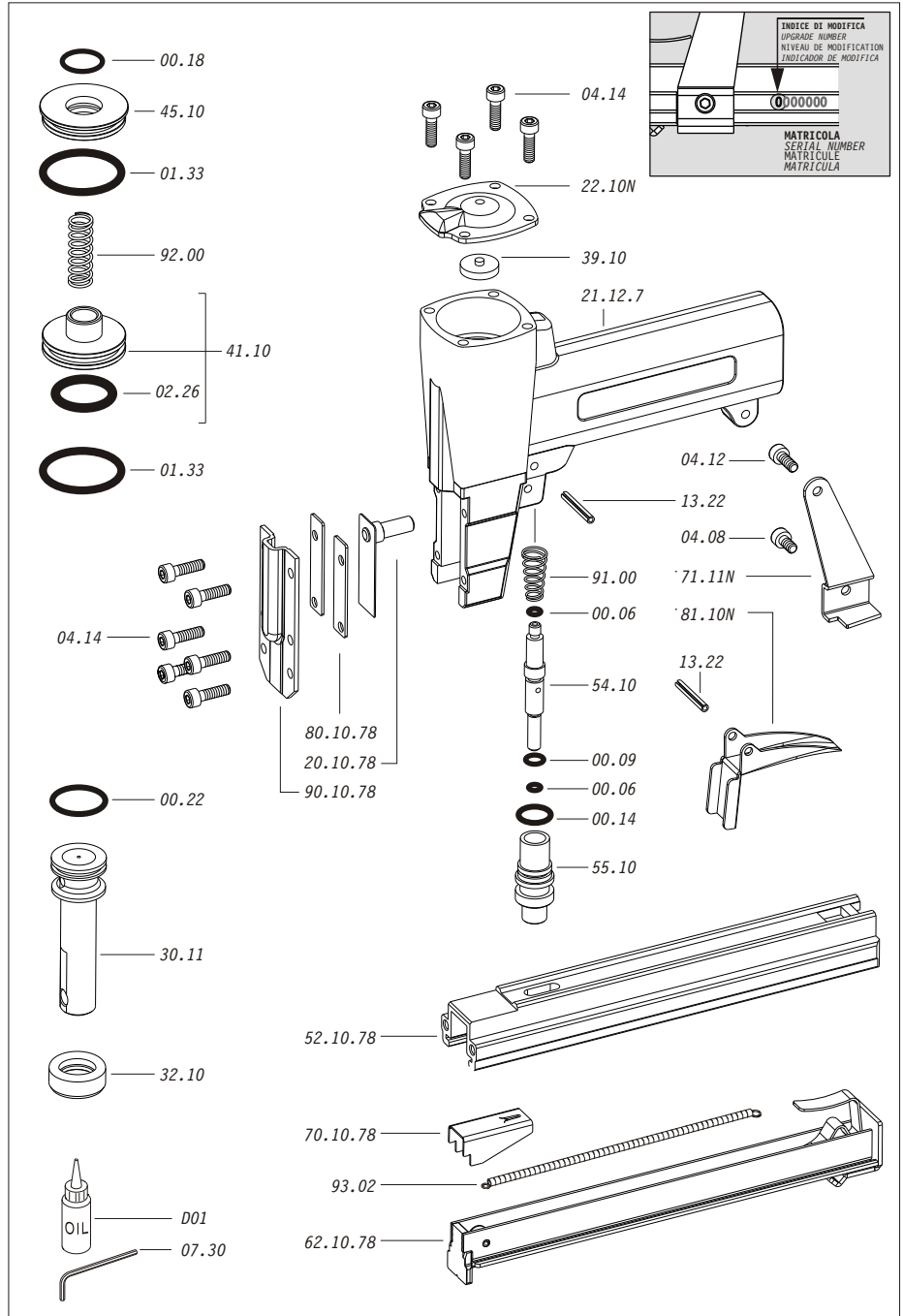

Guarnizioni - O-Rings - Dichtungen - Joints - O-Rings -

- Kit de o-rings - O-ringen - Pakninger

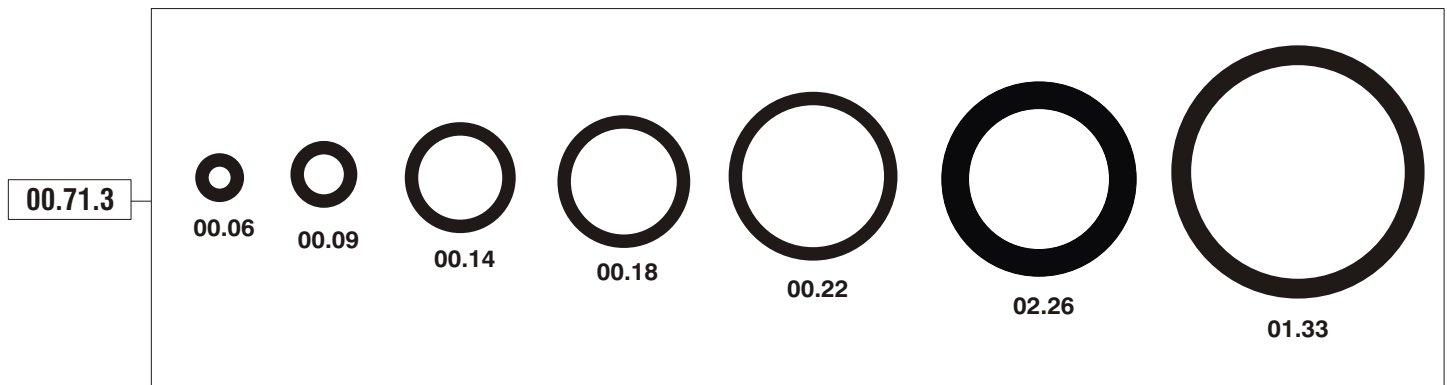

mignon 26

cod. 1055020

Indice di modifica
 Upgrade number

2

2273199