

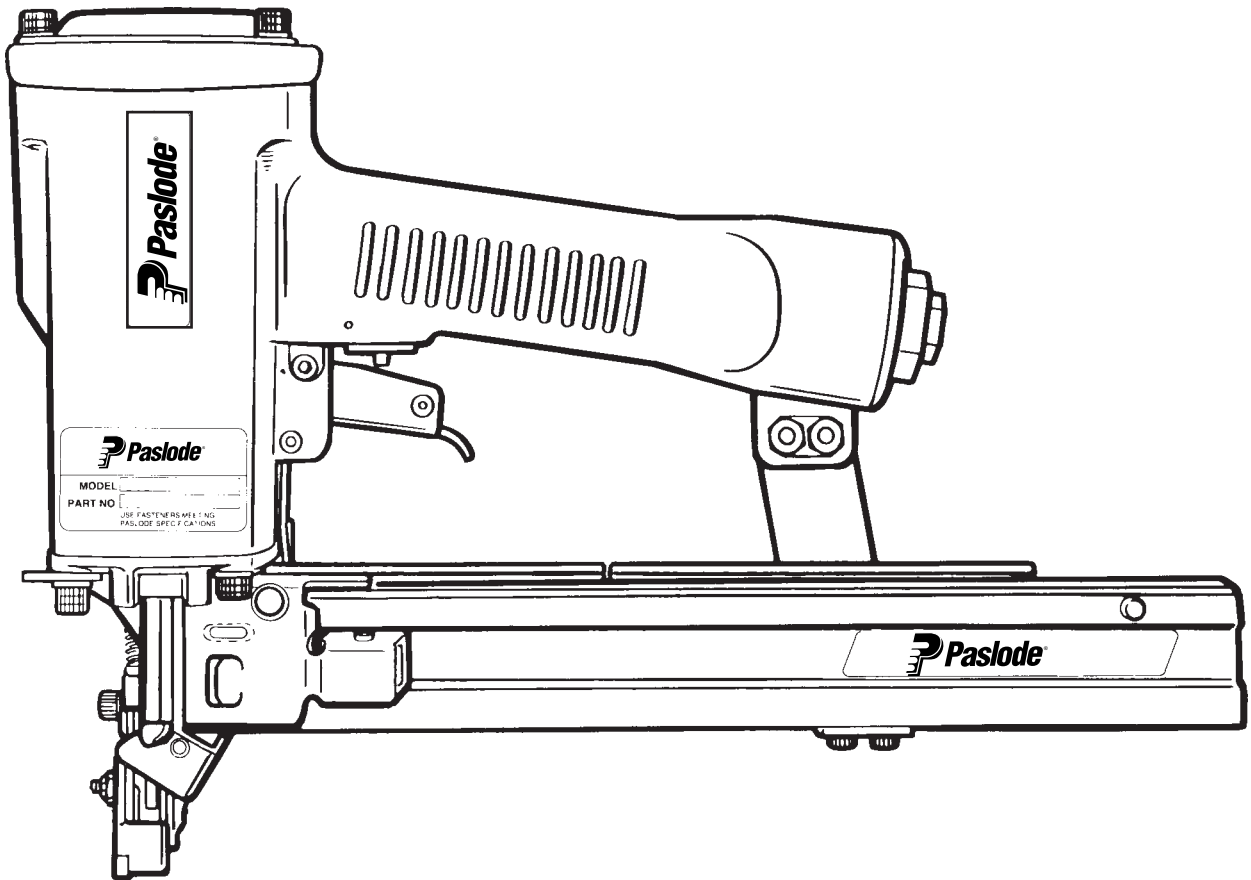

MODEL 3150/38 W16  
MODEL 3200/50 W16  
**WIDECROWN STAPLERS**



## TOOL SCHEMATIC AND PARTS

**IMPORTANT!**  
**DO NOT DESTROY**

Always refer to safety and maintenance manuals #403606, #405218 and #405222 for detailed information on this tool. It is the customer's responsibility to have all operators and service personnel read and understand this information.

# PARTS LEGEND 3200/50 W16, 402775

1	091362	4	Socket Head Capscrew, 1/4 - 20 x 1-1/2"	▲ 48	004224	4	Socket Head Capscrew, #10 - 32 x 3/8"
2	002187	4	Lock Washer, 1/4"	49	403716	2	Socket Head Capscrew 10-32 x 5/16"
3	404242	1	Diffuser Cap	50	402629	2	Hardened Washer
4	006310	1	Socket Head Capscrew, #6 - 32 x 1/2"	51	402737	1	Intermediate Work Contacting Element
6	402704	1	Cap	*52	402738	1	Spring
7	402717	1	Conical Spring	53	402736	1	Flat Washer, #10
*8	404230	1	Retaining Ring	54	402608	1	Work Contacting Element
*9	091537	1	"O" Ring, Main Valve Assembly	55	402763	1	Upper Work Contacting Element
10	404122	1	Upper Valve Piston	*56	402734	1	Spring
11	404055	1	Post, Main Valve	57	402756	1	Front Guide (3150/38)
*12	404256	1	"O" Ring, Main Valve Post		402773	1	Front Guide (3200/50)
*13	402723	1	"O" Ring, Piston	58	404054	1	Seal, Main Valve
14	403563	1	Piston	59	404698	2	Roll Pin Assembly
15	403582	1	Jam Nut	60	404843	1	Back Plate (3150/38)
*16	404182	1	Driver Blade		404845	1	Back Plate (3200/50)
17	402725	1	Seal, Sleeve	61	402730	1	Pivot Pin, Front Guide
18	405245	1	Sleeve	62	402762	1	Roll Pin, 5/32" Dia. x 1-3/4" Lg.
*19	402728	1	"O" Ring, Sleeve	63	405078	1	Spring, Front Guide Latch (3150/38)
*20	402729	1	"O" Ring, Sleeve		405079	1	Spring, Front Guide Latch (3200/50)
21	403854	1	Retainer, Bumper	64	402761	1	Latch, Front Guide (3150/38)
22	403855	1	Bumper		402776	1	Latch, Front Guide (3200/50)
23	402754	1	Seal, Driver Blade	65	402486	1	Retaining Washer
24	402707	1	Gasket, Cap	**66	500459	1	Warning Sign
25	402701	1	Housing	67	402748	1	Pivoting Rail Cover Assembly (3150/38)
26	404939	2	Logo, Housing		402780	1	Pivoting Rail Cover Assembly (3200/50)
27	500685	1	Nameplate (3150/38)	68	404848	1	Rail and Rail Cover Assembly (3150/38)
	500687	1	Nameplate (3200/50)		404849	1	Rail and Rail Cover Assembly (3200/50)
28	402708	1	Gasket, Flange	69	402731	1	Logo, Rail
29	402706	1	Flange	70	402740	1	Roll Pin, 3/32" Dia. x 7/16 Lg.
30	091545	4	Socket Head Capscrew, 1/4 - 20 x 7/8"	71	402758	1	Latch, Follower
31	405144	1	Trigger	72	402759	1	Spring, Follower Latch
32	402079	1	Pin, Trigger	▲ 73	091568	1	Binding Head Screw, #6 - 32 x 1/4"
33	402668	1	Retaining Washer	*74	091532	1	Negator
34	405147	1	Lever, Trigger	75	091534	1	Drum, Negator
35	005849	1	Roll Pin	76	402743	1	Pin, Negator Drum
37	026133	2	Roll Pin, 1/8" Dia. x 1" Lg.	77	402760	1	Follower
38	401958	1	Valve Body	78	404325	1	Stop Nut, #8-32
*39	092174	1	"O" Ring, Valve Body	79	091447	4	Flat Washer
40	097746	1	Valve Pin	80	404243	4	Spacer, Diffuser
41	097748	1	Spring, Valve Pin	*81	090927	1	"O" Ring
*42	091591	1	"O" Ring, End Plug	*82	092775	1	"O" Ring
▲ 43	401940	1	End Plug	*83	092773	1	"O" Ring
44	091622	1	Reducing Pipe Bushing	84	404056	1	Lower Valve Piston
45	004502	4	Socket Head Capscrew, #10 - 32 x 5/8"	85	405243	1	Flange, Sleeve
46	092037	5	Lock Nut, #10 - 32	86	091966	1	O-Ring
47	402781	1	Rail Bracket	87	500488	1	Grip Handle

\* Denotes normal wear items.

\*\* Make sure warning label (500459) is properly affixed. Replace if necessary. Label available at no charge through the Service Dept.

▲ Apply Loctite 242 (Blue) Part No. 093500

➔ Denotes new change.

**AIR CONSUMPTION CHART**

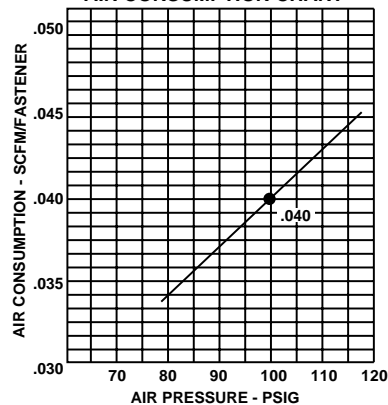

3150/38 W16

402750

3200/50 W16

402775

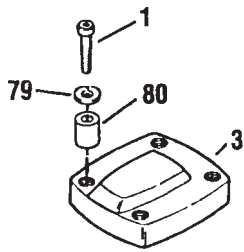

**Cap Assembly #402709**

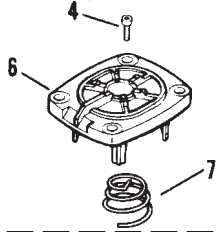

**Main Valve Assembly #404188**

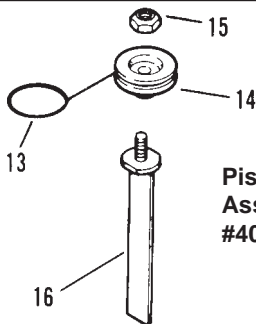
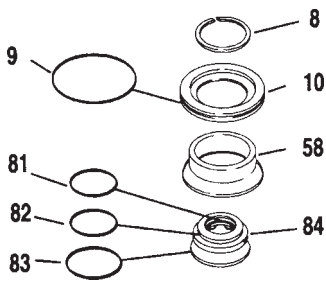

**Piston Assembly #404345**

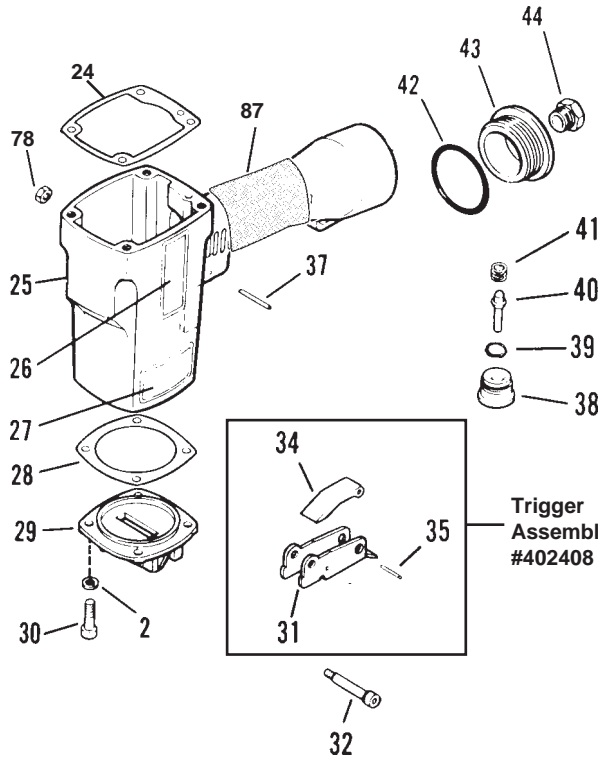
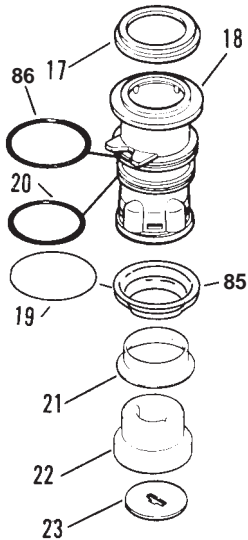

**Trigger Assembly #402408**

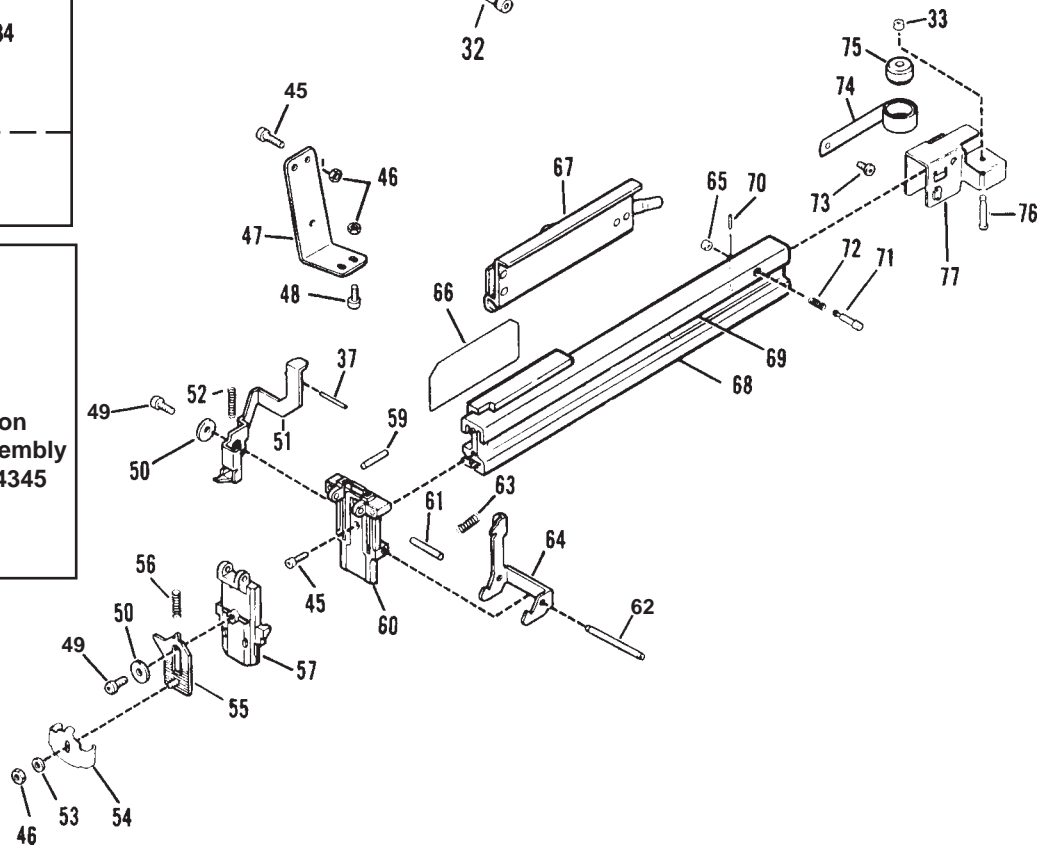

**WARNING**

All parts must be periodically inspected and replaced if worn or broken. Failure to do this can affect the tool's operation and present a safety hazard

# ACCESSORIES

## Sequential Operating Kit

This special attachment is designed for sequential operation (stops "contact" firing). The operator must depress and hold the work contacting element against the worksurface before pulling the trigger. This sequence must be repeated each time the tool drives a fastener.

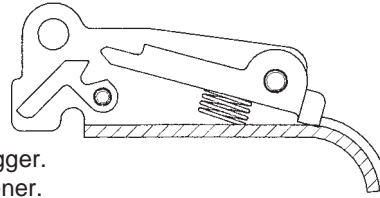

Part No. 406006

## Remote Fire Valve

This valve via a positive air signal allows a machine mounted tool to be operated from an automatic air valve or foot pedal system.

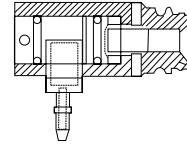

Part No. 1X0713

## Rear Activating Foam Contacting Element

This is a rear-activating, welded-wire work contacting element. It replaces the standard 3000-W16 series work contacting element where rear activation is needed.

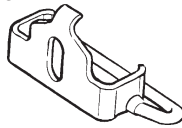

Part No. 1X1026

## Adjustable Foam Contacting Element

This is a wide-foot, cast and brazed assembly that replaces the standard 3000-W16 series work contacting element. This assembly is intended for foam sheathing applications and on machine-mounted tools.

Note: Must be used in combination with #402763 Upper WCE

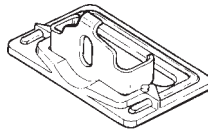

Part No. 402997

(← This item is standard on the 3150/38 W16BF only.)

→ **Large Nylon Tool Bag**

Part No. 219046

## Safety Glasses

Clear Part No. 402510  
Tinted Part No. 402512

## Belt Hook

Attaches to cap of tool enabling you to carry tool on belt holder. Part No. 219017

## Belt Hook Holder

Attaches to work belt and carries tool using the above belt hook. Part No. 219028

## Wide Crown Stapler Repair Kit

This kit repairs all air leaks except for the trigger valve. Part No. 219220

## Trigger Valve Repair Kit

This kit repairs all trigger valve air leaks. Part No. 219224

## Lubricants and Loctite

Chemplex 710 Lubricant 1 lb. Part No. 403734  
Chemplex 710 Lubricant 5 gram tubes Part No. 219188  
Loctite 242 (Blue) 1 oz. Part No. 093500  
Lubricating Oil 16 oz. Part No. 403720 ←  
Lubricating Oil 8 oz. with Antifreeze Part No. 219090

## Degreaser Cleaner

Ideal cleaner for all Paslode tools. Part No. 219086

# SAFETY INSTRUCTIONS

WEAR EYE AND HEARING PROTECTION

DO NOT EXCEED MAXIMUM RECOMMENDED AIR PRESSURE



Always wear hearing protection and eye protection devices, including side shields when operating or working in the vicinity of a tool.

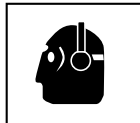

Never use any bottled air or gases such as oxygen to operate the tool since they could cause the tool to explode.

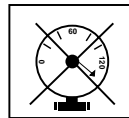

Operate the tool using only the recommended air pressure. Do not exceed the maximum air pressure marked on the tool. Be sure the air pressure gauge is operating properly and check it at least twice a day.

