

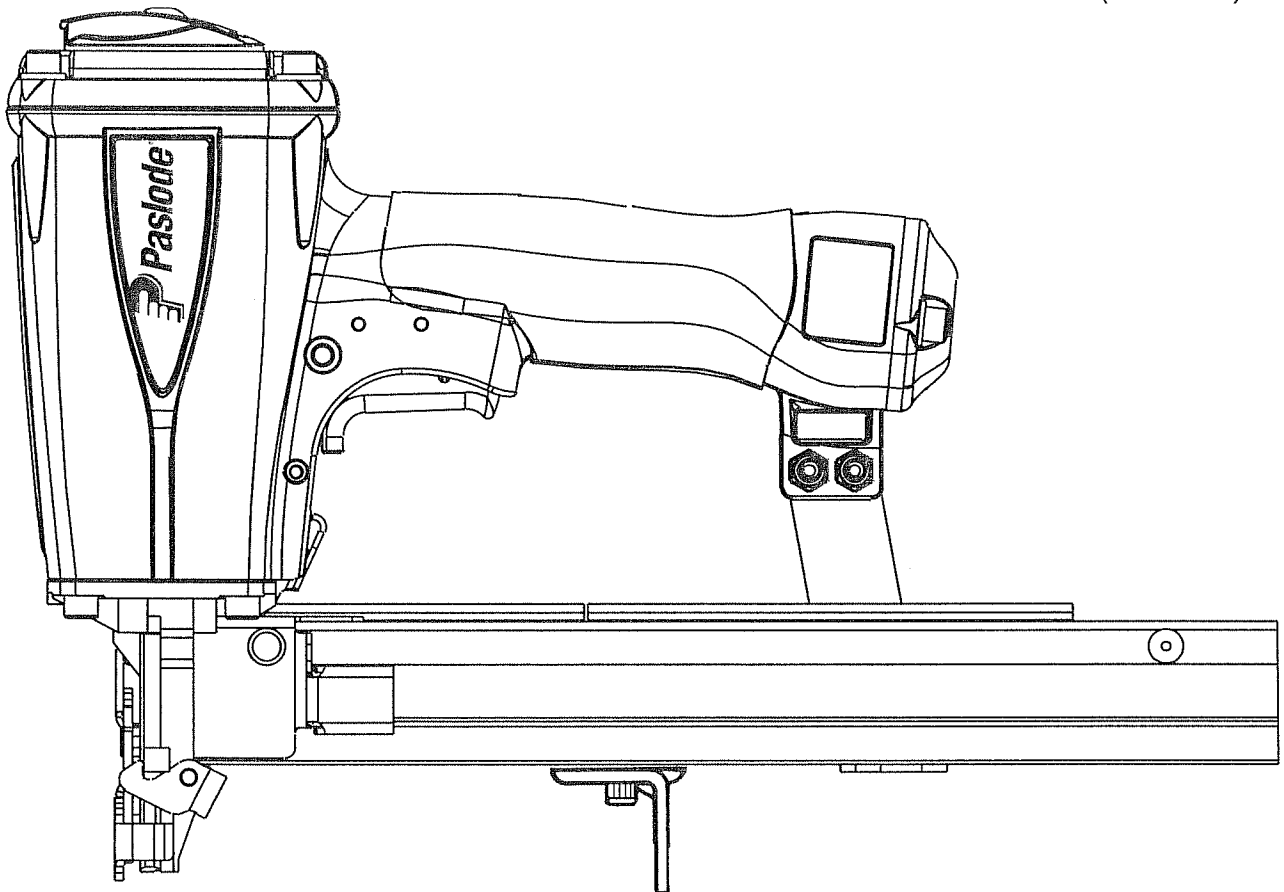

CONSTRUCTION STAPLER
MODEL S150 W16R
WIDECROWN (15/16")



TOOL SCHEMATIC AND PARTS

IMPORTANT!

DO NOT DESTROY

Always refer to safety and operating manuals, #403606, #405218 and #405222 for detailed information on this tool. It is the customer's responsibility to have all operators and service personnel read and understand this information.

PARTS LEGEND

S150 W16R, 501270

1	501043	1	T.H.S.C.S. 1/4-20 x 1/2"	45	402668	2	Retaining Washer
2	500956	1	Cap Diffuser	46	501008	1	Trigger Lever
3	501299	6	S.H.C.S. 1/4-20 x 1-1/2"	47	501010	1	Trigger
4	501254	1	Cap	48	501009	1	Roll Pin
5	402717	1	Conical Spring	49	402669	1	Trigger Pin
* 6	404230	1	Retaining Ring	50	092037	6	Locknut
7	501250	1	Upper Valve Piston	▲ 51	004502	4	S.H.C.S. 10-32 x 5/8"
* 8	091452	1	O-Ring	52	402741	1	Rail Bracket S150
9	404054	1	Seal, Main Valve	▲ 53	004224	3	S.H.C.S. 10-32 x 3/8"
10	404056	1	Lower Valve Piston	54	402743	1	Pin Negator Drum
* 11	090927	1	O-Ring, Main Valve	55	091534	1	Drum, Negator
* 12	092775	1	O-Ring, Main Valve	56	091532	1	Negator
* 13	092773	1	O-Ring, Main Valve	▲ 57	091568	1	Bd. Head Screw 6-32 x 1/4"
* 14	404256	2	O-Ring, Main Valve	58	402760	1	Follower
15	500954	1	Post, Main Valve	59	402486	2	Retaining Washer
16	015660	1	S.H.C.S. 10-24 x 1/2"	60	402758	1	Latch Follower Button
17	403582	1	Driver Blade Nut	61	402759	1	Spring Follower Latch
* 18	405430	1	O-Ring, Piston	62	402740	1	Roll Pin 3/32 x 7/16
19	501252	1	Piston	63	402748	1	Pivot Rail Cover Assembly
* 20	404182	1	Driver Blade	64	501293	1	Nameplate
21	501322	1	Sleeve Retainer	65	404848	1	Rail & Rail Cover Assembly
22	402725	1	Seal Sleeve	** 66	500459	1	Warning Label
23	405243	1	Flange Sleeve	67	404698	2	Roll Pin Assembly
24	501251	1	Sleeve	68	402730	1	Pivot Pin Front Guide
* 25	402728	1	O-Ring, Sleeve	69	405079	1	Spring Front Guide Latch
* 26	091966	1	O-Ring, Sleeve	70	501207	1	Latch Front Guide
* 27	500369	2	O-Ring, Sleeve	71	501209	1	Latch Pin
28	501227	1	Bumper Retainer	72	501204	1	Back Plate
29	500975	1	Gasket Cap	73	501210	1	Front Guide
30	501140	1	Logo Housing Left	74	402734	1	Spring W.C.E.
31	501141	1	Logo Housing Right	→ 75	402763	1	Upper W.C.E.
32	402708	1	Gasket Nose Flange	76	402629	2	Hardened Washer
33	501229	1	Bumper	77	403716	2	S.H.C.S. 10-32 x 5/16"
34	402754	1	Seal Driver Blade	78	404699	1	Lower W.C.E. Assembly
35	402706	1	Flange Nose	79	402736	1	Flat Washer #10
36	091545	4	S.H.C.S. 1/4-20 x 7/8"	* 80	402738	1	Spring
37	501023	1	Grip Handle	81	501320	1	Guide Block
38	500957	1	Housing	82	071297	1	Roll Pin 1/8 x 1-1/8"
39	500963	1	End Plug	83	501244	1	Intermediate W.C.E.
40	097748	1	Spring Valve Pin	84	501253	2	Wear Shield Cap
41	097746	1	Valve Pin	85	501147	1	Wear Plate Flange
42	092174	1	O-Ring, Valve Body	86	402765	1	Lower W.C.E.
43	026133	2	Roll Pin 1/8 x 1	87	403211	1	Rail Wear Button
44	401958	1	Valve Body	88	402769	1	Shingle Guide

* Denotes normal wear items.

** Make sure warning label (500459) is properly affixed. Replace if necessary. Label available at no charge through the Service Dept.

▲ Apply Loctite 242 (Blue) Part No. 093500

→ Denotes new change.

AIR CONSUMPTION CHART

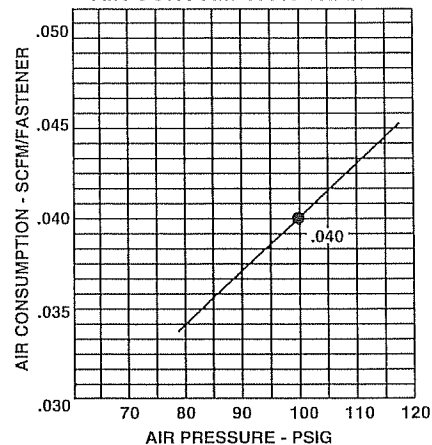

S150 W16R
501270

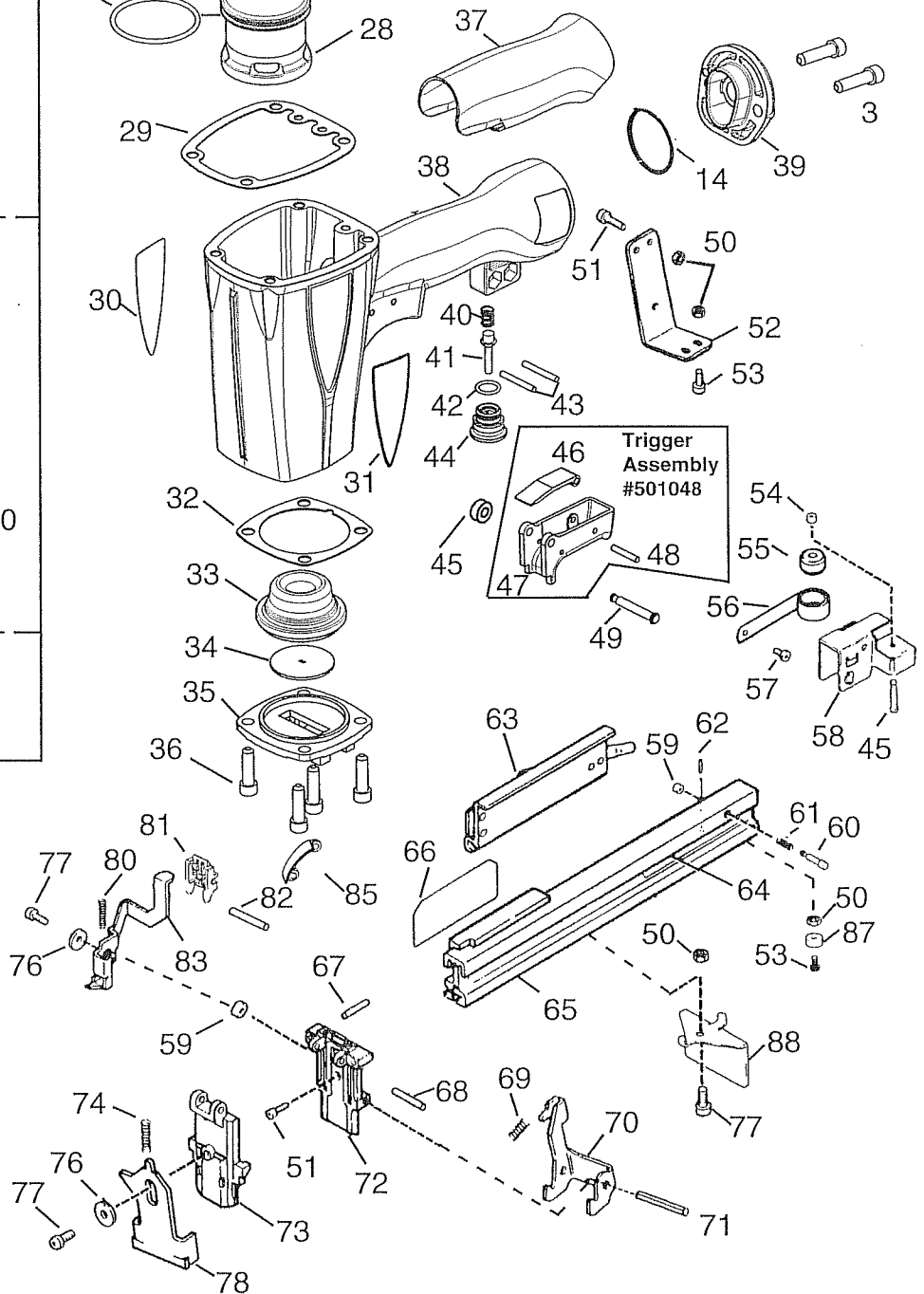
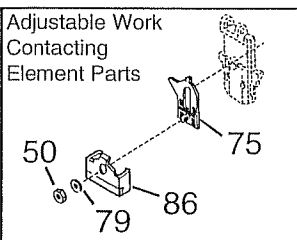
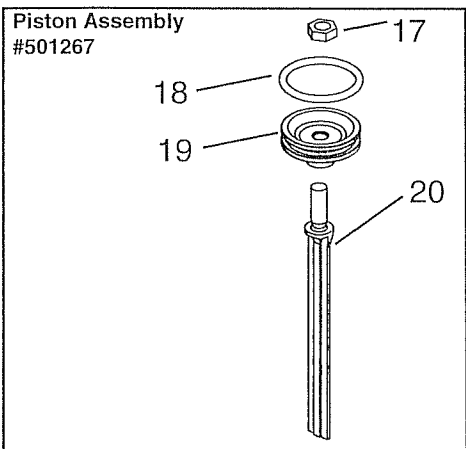
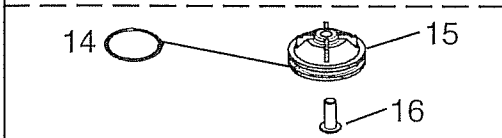
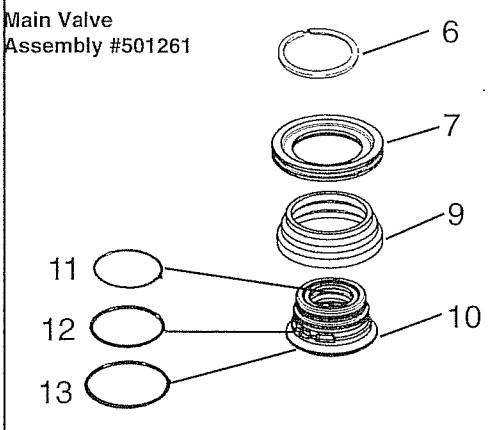
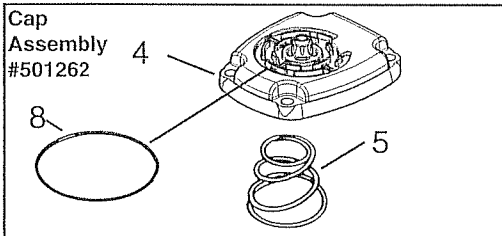
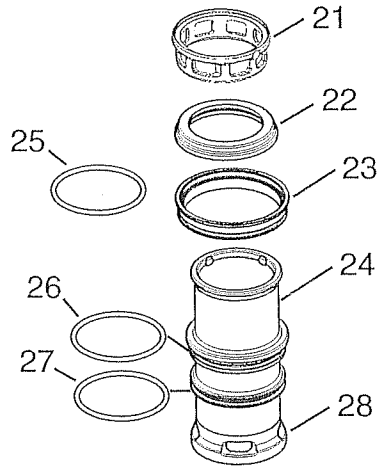
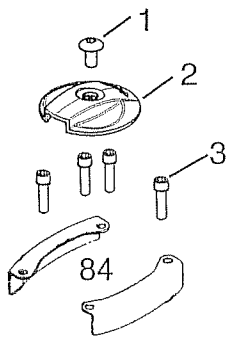

WARNING
All parts must be periodically inspected and replaced if worn or broken. Failure to do this can affect the tool's operation and present a safety hazard

ACCESSORIES

Sequential Operating Kit

This special attachment is designed for sequential operation (stops "contact" firing). The operator must depress and hold the work contacting element against the work surface before pulling the trigger. This sequence must be repeated each time the tool drives a fastener.

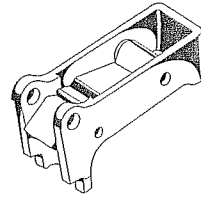

Part No. 501039

Remote Fire Valve

This valve via a positive air signal allows a machine mounted tool to be operated from an automatic air valve or foot pedal system.

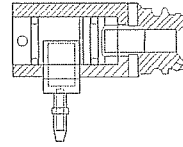

Part No. 1X0713

Large Nylon Tool Bag

Part No. 219246



Safety Glasses

Clear



Part No. 402510

Tinted



Part No. 402512

Belt Hook

Attaches to tool enabling you to carry tool on belt holder.

Part No. 500955

Belt Hook Holder

Attaches to work belt and carries tool using the above belt hook.

Part No. 219028

Trigger Valve Repair Kit

This kit repairs all trigger valve air leaks.

Part No. 219224

Lubricants and Loctite

Lubricant 1 lb.

Part No. 403734

Lubricant 5 gram tubes

Part No. 219188

Loctite 242 (Blue) 1 oz.

Part No. 093500

Lubricating Oil 16 oz.

Part No. 403720

Lubricating Oil 8 oz. with Antifreeze

Part No. 219090

Degreaser Cleaner

Ideal cleaner for all Paslode tools.

Part No. 219086

Adjustable Work Contacting Element Kit

This kit converts the standard work contacting element on the tool to an adjustable work contacting element that allows control of the depth of drive.

Part No. 219259

SAFETY INSTRUCTIONS

WEAR EYE AND HEARING PROTECTION

DO NOT EXCEED MAXIMUM
RECOMMENDED AIR PRESSURE



Always wear hearing protection and eye protection devices, including side shields when operating or working in the vicinity of a tool.

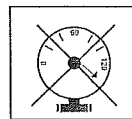

Operate the tool using only the recommended air pressure. Do not exceed the maximum air pressure marked on the tool. Be sure the air pressure gauge is operating properly and check it at least twice a day.

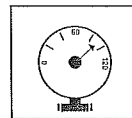

Never use any bottled air or gases such as oxygen to operate the tool since they could cause the tool to explode.



An Illinois Tool Works Company
888 Forest Edge Drive
Vernon Hills, Illinois 60061