

# DIAGRAM OF SN3483H

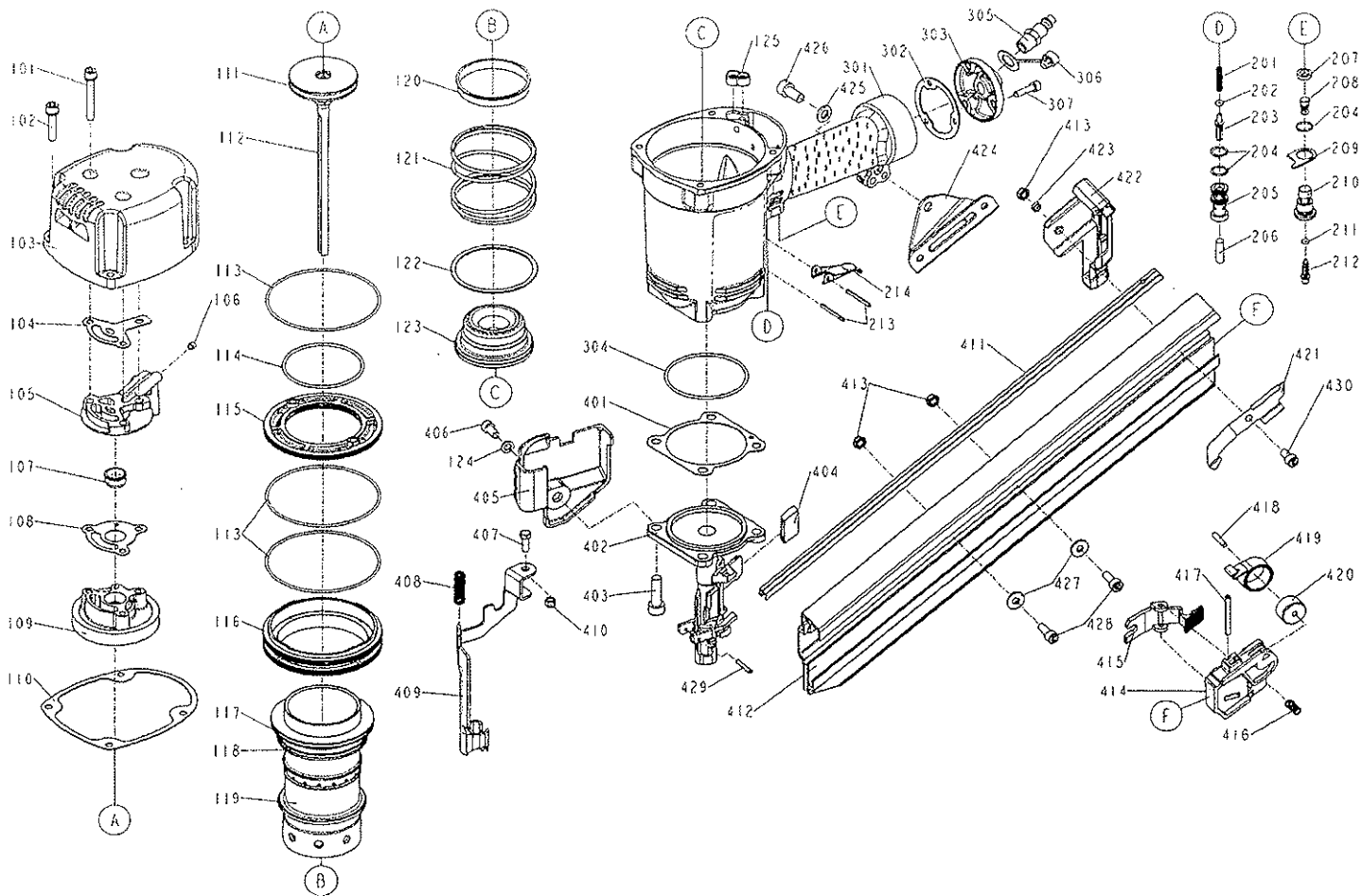

ITEM NO.	PART NO.	DESCRIPTION	ITEM NO.	PART NO.	DESCRIPTION	ITEM NO.	PART NO.	DESCRIPTION
101	820624	BOLT ASSY	209	810540	FIX-PLATE	421	830794	STOP NAIL PLATE
102	820620	BOLT ASSY	210	820351	PLUNGER CAP	422	830795	PROTECTING HOOD COVER
103	820165	CAP	211	830235	O - RING	423	830796	WASHER
104	810631	INLET PACKING	212	820364	PLUNGER	424	830797	POSITIONING SHEET
105	820826	INLET	213	920530	SPRINGER PIN	425	830798	FLAT WASHER
106	920502	HEX.SOC.HD.SCREW	214	810402	TRIGGER	426	830799	HEX.SOC.HD.BOLT
107	820310	SEAL	301	810217	GUN BODY UNIT	427	820811	FLAT WASHER
108	810630	HD.VALVE PISTON PACKING	302	820404	GASKET	428	830800	HEX.SOC.HD.BOLT
109	820140	HD.VALVE PISTON UNIT	303	810920	END CAP	429	820858	SPRINGER PIN
110	820526	CYLINDER CAP SEAL	304	830310	O - RING	430	830801	HEX.SOC.HD.BOLT
111	830224	O - RING	305	920320	AIR PLUG			
112	830780	DRIVER UNIT	306	940620	AIR PLUG CAP			
113	830225	O - RING	307	920730	BOLT ASSY			
114	830312	O - RING	401	820406	GASKET			
115	810531	PRESS RING	402	830781	NOSE PIECE			
116	810525	CYLINDER SPACER	403	820630	HEX.SOC.HD.BOLT			
117	830313	O - RING	404	830782	WASHER			
118	830311	O - RING	405	830783	SAFETY COVER			
119	820527H	CYLINDER	406	820660	HEX.SOC.HD.BOLT			
120	810532H	CYLINDER RING	407	820688	SCREW			
121	810872	COMPRESSION SPRING	408	810805	SAFETY SPRING			
122	820411	WASHER	409	830784	SAFETY UNIT			
123	810612	BUMPER	410	920168	LOCK NUT			
124	820804	FLAT WASHER	411	830785	STEEL CHANNEL			
125	820825	SEAL	412	830786	MAGAZINE A			
201	810367	SPRING	413	830009	LOCK NUT			
202	830236	O - RING	414	830787	PROTECTING HOOD COVER			
203	810911	VALVE PLUNGER	415	830788	PUSHER			
204	830305	O - RING	416	830789	PUSHER SPRING			
205	820329	TRIGGER VALVE HEAD	417	830790	SPIRAL PINS			
206	810718	SAFETY	418	830791	ROLL PIN			
207	820313	SEAL	419	830792	SPRINGER UNIT			