

TP-80/16 (UG/A1-01)

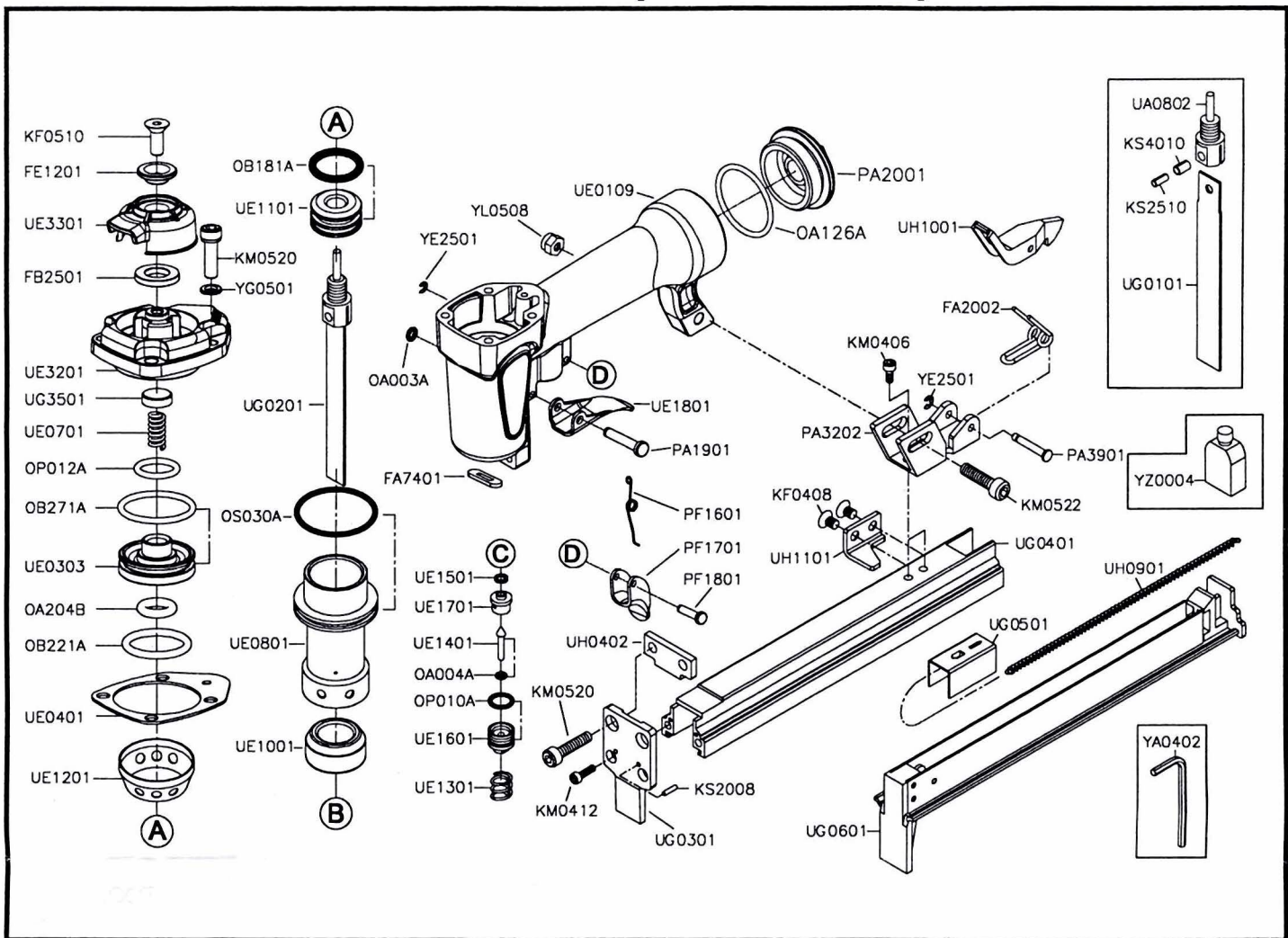

Part_No	Description	Spec	Q'ty	Part_No	Description	Spec	Q'ty	Part_No	Description	Spec	Q'ty
FA2002	LATCH SPRING		1	OP012A	O-RING	P12	1	UE1601	TRIGGER VALVE GUIDE		1
FA7401	NOZZLE		1	OS030A	O-RING	S30	1	UE1701	TRIGGER VALER SEAT		1
FB2501	SEAL		1	PA1901	TRIGGER PIN		1	UE1801	TRIGGER		1
FE1201	EXHAUST CAP RING		1	PA2001	END CAP		1	UE3201	CYLINDER CAP		1
KF0408	BUTTON HD.BOLT	M4× 0.7 - 8L	2	PA3202	SUPPORT		1	UE3301	EXHAUST CAP		1
KF0510	BUTTON HD.BOLT	M5× 0.8 - 10L	1	PA3901	LATCH PIN		1	UG0101	DRIVER		1
KM0406	HEX.SOC.HD.BOLT	M4× 0.7 - 6L	2	PF1601	SAFETY SPRING		1	UG0201	DRIVER ASSY.		1
KM0412	HEX.SOC.HD.BOLT	M4× 0.7 - 12L	2	PF1701	SAFETY LEVER		1	UG0301	COVER PLATE		1
KM0520	HEX.SOC.HD.BOLT	M5× 0.8 - 20L	6	PF1801	SAFETY PIN		1	UG0401	MAGAZINE CAP		1
KM0522	HEX.SOC.HD.BOLT	M5× 0.8 - 22L	1	UA0802	STEM		1	UG0501	PUSHER		1
KS2008	SPRING PIN	∅ 2 - 8L	2	UE0109	BODY		1	UG0601	MAGAZINE ASSY.		1
KS2510	SPRING PIN	∅ 2.5 - 10L	1	UE0303	HEAD VALVE PISTON		1	UG3501	PISTON STOP		1
KS4010	SPRING PIN	∅ 4 - 10L	1	UE0401	CAP SEAL		1	UH0402	GUIDE PLATE		1
OA003A	O-RING	ARP568 - 003	1	UE0701	COMPRESSION SPRING		1	UH0901	PULL SPRING		1
OA004A	O-RING	ARP568 - 004	1	UE0801	CYLINDER		1	UH1001	LATCH		1
OA126A	O-RING	ARP568 - 126	1	UE1001	BUMPER		1	UH1101	MAGAZINE RETAINER		1
OA204B	O-RING (1B)	ARP568 - 204	1	UE1101	MAIN PISTON		1	YAO402	HEX BAR WRENCH	D4	1
OB181A	O-RING	17.5× 3	1	UE1201	COLLAR		1	YE2501	E-RING	∅ 2.5	2
OB221A	O-RING	22× 3	1	UE1301	COMPRESSION SPRING		1	YG0501	SPRING WASHER	∅ 5	4
OB271A	O-RING...	26.8× 2.4	1	UE1401	TRIGGER VALVE STEM		1	YL0508	LOCK NUT	M5× 0.8	1
OP010A	O-RING	P10	1	UE1501	SEAL		1	YZ0004	OIL BOX		1

☆☆ If you need to order parts, please mark both Parts No. and Description. ☆☆